



**Sauter GmbH**

Ziegelei 1  
D-72336 Balingen  
E-mail: [info@sauter.eu](mailto:info@sauter.eu)

Telephone: +49-[0]7433-9933-199  
Fax: +49-[0]7433-9933-149  
Web: [www.sauter.eu](http://www.sauter.eu)

# Instruction Manual Sound Level Meter

## SAUTER SW 1000/SW 2000

Version 1.1  
01/2018  
GB



PROFESSIONAL MEASURING

SW-BA-e-1811



# SAUTER SW 1000/SW 2000

Version 1.1 01/2018

## User Manual Sound Level Meter

Congratulations on your purchase of a high-quality sound level meter by SAUTER. We wish you a lot of pleasure and satisfaction in using our top-quality gauge with a comprehensive range of functions. Should you have any questions, we remain at your disposal.

Table of contents:

<b>Appearance</b> .....	<b>5</b>
<b>Operating keys</b> .....	<b>6</b>
<b>1 Introduction</b> .....	<b>6</b>
1.1 Overview.....	6
1.2 Applications .....	7
1.3 Functions .....	7
1.4 Function updates.....	7
1.5 Specification .....	8
1.6 Information on regular tests.....	10
1.7 Main components .....	10
1.8 List of parts .....	10
1.9 Graphic representation of delivery package .....	11
<b>2 View and operation</b> .....	<b>11</b>
2.1 Keyboard .....	11
2.2 Microphone port .....	12
2.3 Wind shield .....	13
2.4 Data socket and power socket.....	13
2.5 Battery .....	14
2.6 GPS .....	15
<b>3. Measurement screen</b> .....	<b>16</b>
3.1 Screen symbols and their meanings.....	16
3.2 Screen in the level measurement mode.....	17
3.3 1/1 Octave Mode screen.....	19
<b>4. Operation and setting the menu</b> .....	<b>20</b>
4.1 Function .....	20
4.2 Calibration .....	20
4.2.1 Calibration by measurement .....	21
4.2.2 Calibration by calibration factor .....	21
4.2.3 Calculation of calibration factor and sensitivity .....	21
4.2.4 Calibration by measurement .....	21
4.3 Measurement .....	23
4.3.1 Measurement setup.....	23
4.3.2 Measuring range.....	25
4.3.3 ICCP Power.....	25
4.3.5 Alarm Threshold .....	26
4.3.6 Extended Function.....	26
4.3.7 Statistical .....	26
4.3.8 Time History .....	27
4.3.9 Octave Threshold .....	27
4.3.10 Custom Measure .....	27

4.3.11 Timer .....	27
4.3.12 24 h Measurement with Timer .....	28
<b>4.4 Setup.....</b>	<b>29</b>
4.4.1 Contrast .....	29
4.4.2 Backlight .....	29
4.4.3 Battery .....	29
4.4.4 Trigger .....	30
4.4.5 Date & Time.....	30
4.4.6 Auto Power Off .....	31
4.4.7 RS-232 .....	32
4.4.8 File Manager.....	32
4.4.9 Boot Mode .....	33
4.4.10 USB Mode .....	34
4.4.11 GPS .....	35
4.4.12 Setup Template .....	35
4.4.13 About .....	35
<b>4.5 Language.....</b>	<b>35</b>
<b>4.6 Output.....</b>	<b>36</b>
4.6.1 AC OUT .....	36
4.6.2 DC OUT .....	36
4.6.3 Printer .....	37
<b>4.7 Factory Settings .....</b>	<b>37</b>
<b>5. RS-232 Data Transmission Protocol .....</b>	<b>38</b>
<b>5.1 Hardware configuration and interface settings.....</b>	<b>38</b>
<b>5.2 Transmission protocol.....</b>	<b>38</b>
5.2.1 Beginning and end of block transmission.....	39
5.2.2 Device ID .....	39
5.2.3 Attribute character (ATTR) .....	39
5.2.4 Block check character (BCC) .....	39
5.2.5 Block transmission format .....	40
5.2.6 Restoration after transmission errors .....	41
5.2.7 Flow control .....	41
5.2.8 Operation with several devices .....	41
5.2.9 Nominal parameters .....	42
<b>5.3 Instructions .....</b>	<b>42</b>
<b>6. Operation guidelines .....</b>	<b>43</b>
<b>6.1 Operation.....</b>	<b>43</b>
<b>6.2 Troubleshooting .....</b>	<b>43</b>
<b>6.3 Calibration.....</b>	<b>44</b>
<b>6.4 Firmware updating .....</b>	<b>44</b>
6.4.1 Installation of USB driver.....	44
6.4.2 Firmware updating procedure .....	45
<b>6.5 Warranty .....</b>	<b>46</b>
<b>6.6 Service Department telephone number .....</b>	<b>46</b>
<b>Glossary .....</b>	<b>46</b>
<b>Appendix 2 .....</b>	<b>48</b>
<b>Weightings for the sound level meter and sound broadcasting around the microphone at typical building reflections.....</b>	<b>48</b>
<b>Appendix 3 .....</b>	<b>49</b>
<b>Weightings related to the use of a wind shield outdoors .....</b>	<b>49</b>
<b>Appendix 4 .....</b>	<b>50</b>
<b>Electret microphone weightings .....</b>	<b>50</b>
<b>Appendix 5 .....</b>	<b>51</b>
<b>Typical frequency response and corresponding upper limits.....</b>	<b>51</b>

**Appendix 6 ..... 52**  
**Technical data of 1/1-octave filter ..... 52**

**Appearance**



## Operating keys

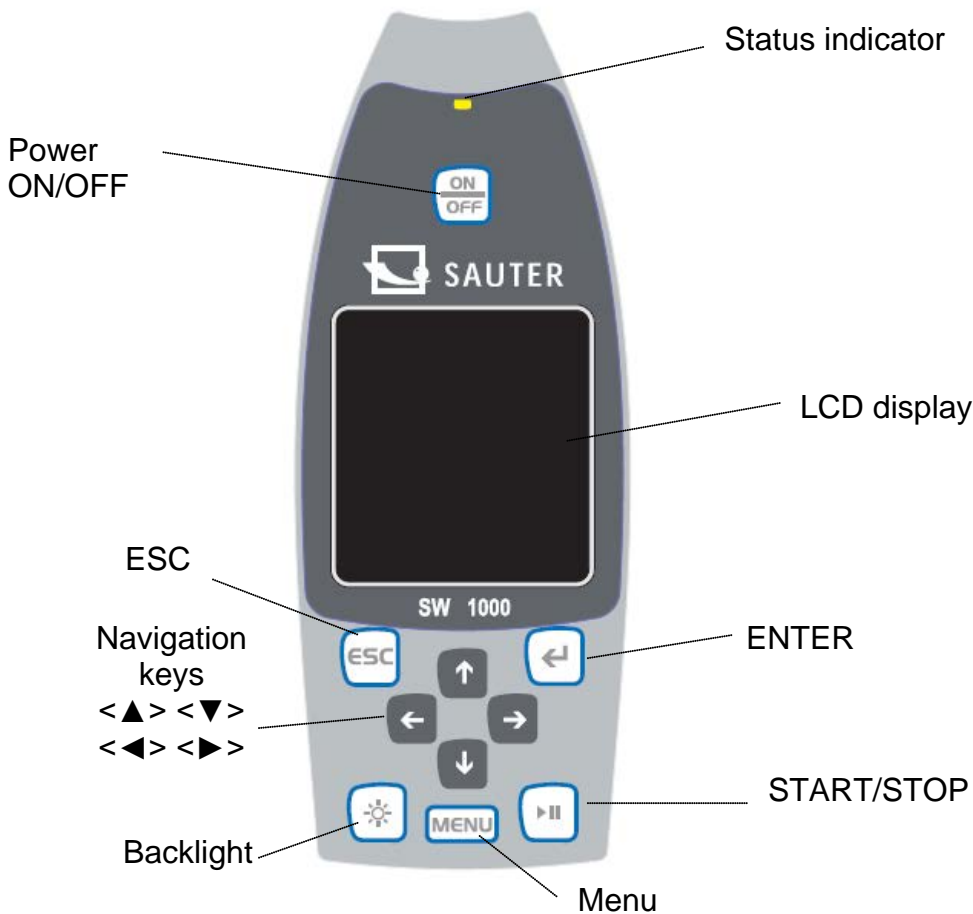

## 1 Introduction

### 1.1 Overview

The **SW 1000/SW 2000** gauges are a new generation of measuring instruments with an octave analyser which meets the market requirements and is based on the basic SW 1000/200 instrument. The meter meets the requirements of IEC standard and the Chinese GB/T standard for measuring instruments with 1/1-octave analysers.

The SW 1000/SW 2000 gauge is a digital sound level meter developed and manufactured by KERN. The instrument with a 24-bit analogue-digital converter with a very high accuracy is a perfect choice for various measuring activities, such as measurement of noise generated in the environment, by vehicles or in industrial applications.

The new types are equipped with a single-chip ARM processor with two cores (DSP+ARM) and a floating-point co-processor, so they perform floating-point calculations instead of fixed-point calculations, which considerably improves their accuracy and stability. The re-designed input module additionally reduces own noises and enhances the linear measuring range. The new algorithm supports only one measuring range which includes a dynamic range above 120 dB, but despite that it still meets the requirements of the standard.

The **SW 1000** meter is a **Class 1** gauge, and the **SW 2000** is a **Class 2** gauge.

## 1.2 Applications

- Simple noise measurements
- Determination of environmental noise
- Product quality control
- Assessment of technical activities for noise reduction

## 1.3 Functions

- Class 1 (**SW 1000**) and Class 2 (**SW 2000**)  
Sound Level Meter
- Meets the requirements of IEC 61672-1:2013, ANSI S1.4-1983 and ANSI S1.43-1997
- The 1/1-octave analyser is in accordance with IEC 61260-1:2014 and ANSI S1.11-2004
- Linearity range: 20 dBA to 134 dBA (**SW 1000**), 25 dBA to 136 dBA (**SW 2000**)
- Dynamic range: above 123 dB for **SW 1000** and above 122 dB for **SW 2000**
- Frequency weighting: A/B/C/Z; time constant: fast/slow/pulse
- 3 profiles and 14 measurements defined by the user and calculated simultaneously with different frequency weightings / time constants
- Calculation of SPL, LEQ, Max, Min, Peak, SD, SEL and E values
- LN statistics and display of the time curve
- User-defined integral interval measurement up to a maximum of 24 hours
- Extremely fast ARM processor with a floating-point coprocessor, ensuring a wide frequency response, high dynamic range and low own noise
- MicroSD (TF) card with 4 GB capacity as a bulk storage carrier
- RS-232 remote control interface
- Thermal mini-printer for printing of measurement data
- Internal GPS module (option), GPS time support

## 1.4 Function updates

➤ Single-chip, extremely fast ARM processor with a floating-point coprocessor	➤ Implemented USB port
➤ LCD display with a white backlight	➤ Firmware updates using the USB port (power supply also through the USB)
➤ Integration period: 1 s to 24 h	➤ Support of automatic measurements with the timer function
➤ New logging steps: 0.1 s, 0.2 s and 0.5 s	➤ Internal GPS module (option) with GPS time support
➤ 5 templates for user data saving	➤ Only one measuring range covering a dynamic range of more than 123 dB
➤ B-weighting complemented with ANSI standard	➤ Low own noise (only in Class 1 gauge)
➤ Automatic activation with an external power supply, easy integration	➤ Upper measuring range limit: 134 dB <sub>eff</sub> /137 dB <sub>eff</sub> (50 mV/Pa)

## 1.5 Specification

Technical data		
Type	SW 1000	SW 2000
Accuracy	Class 1 (Group X)	Class 2 (Group X)
Standard	GB/T 3785.1-2010, IEC 60651:1979, IEC 60804:2000 IEC 61672-1:2013, ANSI S1.4-1983, ANSI S1.43-1997	
Octave <sup>1</sup>	average frequencies of the 1/1-octave filter: 31.5 Hz to 16 kHz GB/T 3241-2010, IEC 61260-1:2014 ANSI S1.11-2004	average frequencies of the 1/1-octave filter: 31.5 Hz to 8 kHz GB/T 3241-2010, IEC 61260-1:2014 ANSI S1.11-2004
Microphone	MPA231T: pre-polarised 1/2" measuring microphone, Class 1, sensitivity: 50 mV/Pa, frequency range: 10 Hz to 20 kHz	MPA200T: pre-polarised 1/2" measuring microphone, Class 2, sensitivity: 40 mV/Pa, frequency range: 20 Hz to 12.5 kHz
Microphone port	TNC connector with ICCP (4 mA) power supply	
Detector/Filter	fully digital signal processing by floating-point coprocessor (digital detector and filter)	
Integration period	User-defined integration period within a range of 1 s–24 h [User]. repetition time: indefinite or 1 to 9999.	
Logging step	0.1 s, 0.2 s, 0.5 s; 1 s to 24 h	
Measuring functions	L <sub>XY(SPL)</sub> , L <sub>Xeq</sub> , L <sub>XYSD</sub> , L <sub>XSEL</sub> , L <sub>XE</sub> , L <sub>XYmax</sub> , L <sub>XYmin</sub> , L <sub>XPeak</sub> , L <sub>XN</sub> . Where: X means frequency weighting: A, B, C, Z; Y means time constant; F, S, I; N means statistic measurement: 1 to 99; 3 profiles and 14 user-defined measurements calculated simultaneously with different frequency weightings / time constants	
24 h measurement	automatic measurement as per the date and time settings defined by the customer, and history data recording	
Frequency weighting	parallel: A, B, C, Z	
Time constant	parallel detection of F, S, I and Peak values	
Own noise <sup>2</sup>	sound: 18 dB(A), 23 dB(C), 31 dB(Z) electrical data: 11 dB(A), 16 dB(C), 21 dB(Z)	sound: 20 dB(A), 26 dB(C), 31 dB(Z) electrical data: 14 dB(A), 19 dB(C), 24 dB(Z)
Upper limit <sup>2</sup>	134 dB(A) increase up to 154 dB(A) using a 50 mV/Pa microphone	136 dB(A) increase up to 154 dB(A) using a 50 mV/Pa microphone
Frequency response <sup>1</sup>	10 Hz to 20 kHz	20 Hz~12.5 kHz
Linearity Range <sup>2, 3</sup>	20 dB(A) to 134 dB(A)	25 dB(A) to 136 dB(A)
Dynamic range <sup>2</sup>	123 dB (11 dB(A) to 134 dB(A))	122 dB (14 dB(A) to 136 dB(A))
Peak-C range <sup>2, 3</sup>	45 dB(A) to 137 dB(A)	47 dB(A) to 139 dB(A)
Electrical input	maximum input voltage: 5 V <sub>eff</sub> (7.07 V <sub>peak</sub> ) input impedance of pre-amplifier > 6 GΩ	
Range setting	one range covering the entire dynamic range	



Resolution	24 bits
Sampling frequency	48 kHz
Time history	displaying noise characteristics as a function of time, duration of measurement: 1 minute, 2 minutes, 10 minutes
LCD indicator	LCD display, 160 x 160, with white backlight, 14 contrast levels, readouts updated every 1 s
Bulk storage	microSD (TF) card with a capacity of 4 GB
Final processing	VA-SLM software for final processing: readout, analysis and report generation based on the data saved
Data export	direct computer connection to read the content of memory card (as a USB disk)
Output	AC output (maximum 5 V <sub>EFF</sub> , ±15 mA), DC output (10 mV/dB, maximum 15 mA), serial RS-232 interface and USB port (USB Disk Mode and Modem Mode)
Alarm	user-defined LED indicator alarm threshold for alarm status displaying
Setup template	5 templates for saving of user settings for different applications, the template can be stored in the microSD card
Automatic activation	automatic activation and initiation of measurement by applying the operating voltage, easy integration
Power supply	4 alkaline 1.5 V batteries (LR6/AA/AM3) are sufficient for approx. 10 hours (depending on the battery), the working voltage can also be supplied by a direct current source (7–14 V, 500 mA) and a USB port (5 V, 1 A)
Real time clock (RTC)	integrated buffer battery was factory calibrated with an error of < 26 s in 30 days (< 10 ppm, (25 ±16)°C); the buffer battery ensures an operating continuity of the system clock also during replacement of the main batteries available GPS time function (option with GPS module)
Language	English, Chinese, Portuguese, Spanish, German, French
Firmware updating	firmware updated using the USB port
Conditions	temperature: –10°C to 50°C; humidity: 20–90%, relative humidity
Real-time temperature	indication of real-time temperature on the main screen
Dimensions (mm)	70 x 300 x 36 (W x H x D)
Weight	approx. 620 g with 4 alkaline batteries
<b>Option</b>	
GPS	type of receiver: 50-channel receiver time to initial measurement: cold start 27 s, warm start 27 s, hot start 1 s

	sensitivity: tracking –161 dBm, new measurement –160 dBm, cold start –147 dBm, hot start –156 dBm horizontal accuracy of position indication: 2.5 m accuracy of time indication: 30 ns, accuracy of speed indication: 0.1 m refreshing frequency: 1 Hz operating range limits: dynamics $\leq 4$ g, height $< 50,000$ m, speed $< 500$ m/s
Calibrator	CA111, Class 1, 94 dB/114 dB, 1 kHz
Printer	thermal mini-printer, RS-232 socket
Hint 1:	For the BSWA 200 gauges, any result above 12.5 kHz can be ignored due to the frequency response of the microphone installed in Class 2 gauges.
Hint 2:	The data were measured using a 50 mV/Pa microphone for SW 1000 meter and a 40 mV/Pa microphone for BSWA 200 meter.
Hint 3:	The measurement meets the requirements of GB/T3785 and IEC 61672 standards.

## 1.6 Information on regular tests

- Reference sound level: 94.0 dB
- Reference direction of incidence: parallel to the microphone direction
- Microphone reference point: centre of the microphone membrane
- Reference direction of incidence: vertical relative to the microphone membrane

## 1.7 Main components

Name	Manufacturer	Type	Description
Microphone		SW-A01	class 1 microphone
		SW-A02	class 2 microphone

## 1.8 List of parts

No.	Type	Description
<b>Standard</b>		
1	SW 1000/2000	sound level meter without microphone
2		ICCP pre-amplifier with TNC connector
3	SW-A01/SW-A02	class 1 microphone (1000) or class 2 microphone (200)
4	Wind shield SW-A03	90 mm wind shield, diameter up to the microphone: 1/2"
5	microSD card SW-A04	4 GB memory card for data storage
6	Battery	4 alkaline batteries (LR6/AA/AM3)
7	Power unit	9 V/500 mA power unit

8	Mini USB cable	for computer connection
<b>Option</b>		
1		GPS module and antenna
2	Tripod SW-A05	stand for the sound level meter
3	Printed user manual	printed user manual

## 1.9 Graphic representation of delivery package

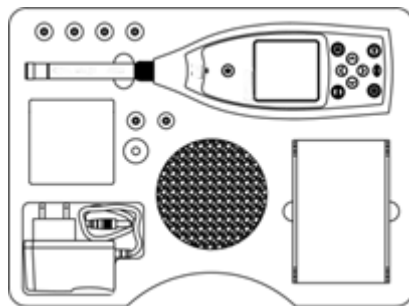

☆ Hint: The details specified in the list of parts may differ depending on the delivery.

## 2 View and operation

The look of SW 1000 and SW 2000 gauges and keyboards is identical. The LCD display, keyboard and LED indicators are located on the front side.

### 2.1 Keyboard

The sound level meter is provided with 10 keys:



#### <START/STOP>:

To switch on the sound level meter, press and hold this key for 2 s. If the meter is frozen at the Stop status, press and hold the key for 2 s to open the switch-off dialogue box, and then press <ENTER> to switch on the sound level meter.

☆ Hint: The <ENTER> key does not work during measurement.

#### <ESC>:

It is used to quit the menu and go back to the previous menu. The <ESC> key is also used to delete the history curve at the time history display.

#### <ENTER>:

It is used to call a next menu level, to confirm a change of parameters or to save the current data in CSD format when the gauge is switched off.

**<Backlight>:**

It is used to switch on/off the LCD display: you can set the backlight delay in the menu. Further details are provided in section [4.4.2 Backlight](#).

**<START/STOP>:**

It is used to start/stop the measurement.

**<▲>:**

The up arrow key is used to choose the options on the menu or to change the parameters.

**<▼>:**

The down arrow key is used to choose the options from the menu or to change the parameters.

**<◀>:**

The left arrow key is used to choose the options from the menu, to change the parameters or to switch between the measurement screens.

**<▶>:**

The right arrow key is used to choose the options from the menu, to change the parameters or to switch between the measurement screens.

**<MENU>:**

It is used to open the main menu list.

**2.2 Microphone port**

The TNC connector located on top is used to connect the microphone and pre-amplifier (normally the microphone and pre-amplifier are installed together in a single casing). The TNC connector is a threaded concentric connector.

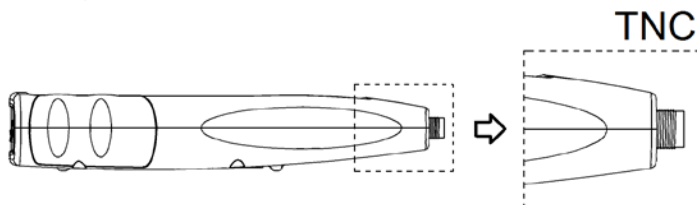

The **SW 1000** gauge is equipped with a Class 1 microphone, and the **SW 2000** gauge – with a Class 2 microphone:

**SW-A01:**

Pre-polarised 1/2" measuring microphone, Class 1. Sensitivity: 50 mV/Pa. Frequency range: 10 Hz to 20 kHz. Common casing with an ICCP pre-amplifier, power supply: 4 mA/24 V.

**SW-A02:**

Pre-polarised 1/2" measuring microphone, Class 2. Sensitivity: 40 mV/Pa. Frequency range: 10 Hz to 12.5 kHz. Common casing with an ICCP pre-amplifier, power supply: 4 mA/24 V.

The microphone and pre-amplifier are interconnected (screwed) with a thread. Do not disconnect them under any circumstances. The microphone is an accurate measuring sensor – a long contact with an environment of a high humidity or dustiness may cause its damage. If the microphone is not used, store it in the box provided.

The microphone is equipped with an ICCP power supply. Current technical data of the power supply: 4 mA, 24 V. Voltage over 30 V may cause damage to the microphone. The SW 1000/SW 2000 sound level meter is equipped with an internal ICCD power supply which allows a direct connection of a microphone.

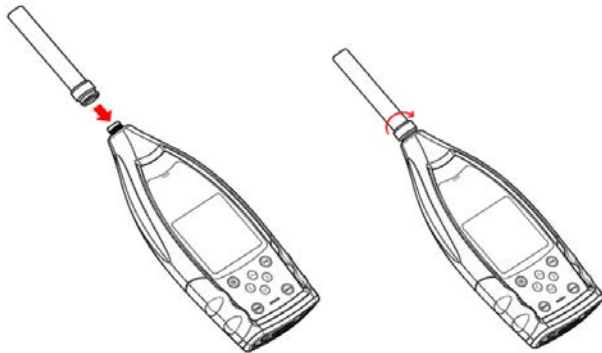

Connect the microphone to the TNC connector. Then turn it on the thread, firmly connecting both elements.

### 2.3 Wind shield

The sound level meter is supplied with a WS002-9 wind shield used outdoors in windy environments. Do not use the wind shield if the environment is not exposed to wind (e.g. when performing measurements indoors).

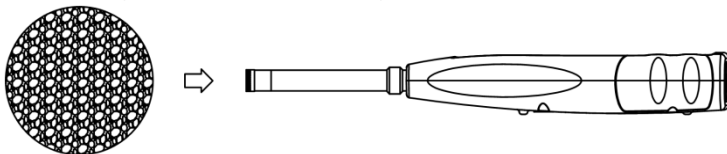

Firmly press the wind shield onto the microphone all the way, as shown in the figure above. Further details concerning the wind shield correction outdoors are specified in Appendix 4.

### 2.4 Data socket and power socket

The bottom part of the sound level meter includes 7 sockets. Open the rubber cover to see them.

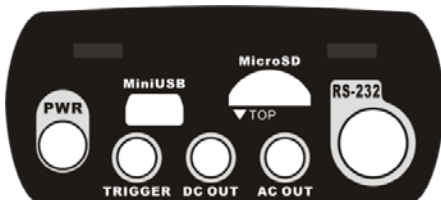

#### PWR:

Standard DC power socket (diameter: 2.1 mm) allows you to connect an external power unit of 7–14 V, 500 mA.

☆ **Hint:** Any external voltage exceeding 14 V may damage the sound level meter!

#### MiniUSB:

The miniUSB port for computer connection in the **USB Disk Mode** or **Modem Mode**; further information – see [4.4.10 USB Mode](#). The miniUSB port can also

be used as an additional external power supply; the power supply must provide 5 V/1 A.

**USB Disk Mode:** It enables a direct interference in the files stored in the microSD card; it does not require driver installation.

The miniUSB port is detected by the computer as a serial port (virtual serial port, driver installation required), and the communication with the sound level meter is via the RS-232 interface; further information – see section RS-2325 Data Exchange Protocol.

☆ **Hint:** **The power supply must provide a current of minimum 1 A, and the cable must ensure the flow of such current (do not use ferrite balls for power supply).** Choose the operating mode after connecting the device to the computer. Otherwise the USB port may not be detected by the computer. If you choose the **modem mode**, a simultaneous operation of the miniUSB and RS-232 ports is impossible.

#### **MicroSD card:**

MicroSD card socket: used to connect the microSD card to save SWN, OCT and CSD files. We recommend using a card reader, not the **USB Disk Mode**, for microSD card formatting. The microSD card delivered with the sound level meter is pre-formatted.

☆ **Hint:** When inserting the microSD card, hold it face front (anti-scratch protection).

#### **RS-232:**

The socket can be used as a standard RS-232 interface in the **remote mode** and to connect a thermal printer in the **printer mode**. Detailed information, see [4.6.3 Printer](#) and [5. RS-232 Data Exchange Protocol](#).

#### **TRIGGER:**

Trigger input with a standard 3.5 mm headphone socket. Detailed information, see [4.4.4 Trigger](#).

#### **DC OUT:**

DC output with a standard 3.5 mm headphone socket. Detailed information, see [4.6.2 DC OUT](#).

#### **AC OUT:**

AC output with a standard 3.5 mm headphone socket. Detailed information, see [4.6.1 AC OUT](#).

## **2.5 Battery**

We recommend using 4 alkaline batteries (LR6/AA/AM3); consider the battery polarity (+/-) and marking in the battery container. Do not use old and new batteries at the same time. Take out the batteries if the device is not used. The total voltage at 4 battery cells should not exceed 14 V, otherwise the sound level meter may get damaged.

Practical tests have shown that 4 alkaline battery cells are sufficient for almost 10 operating hours (depending on the batteries). If you use Eneloop BK-3HCCA/4BC batteries (rated capacity: 2,450 mAh), the sound level meter can operate continu-

ously for almost 12 hours. If the battery voltage drops below the minimum voltage required for the meter operation, the gauge will automatically switch off.

In case of a long operation, we recommend using an external power supply or USB power supply.

Insert and replace the batteries as shown in the figure below:

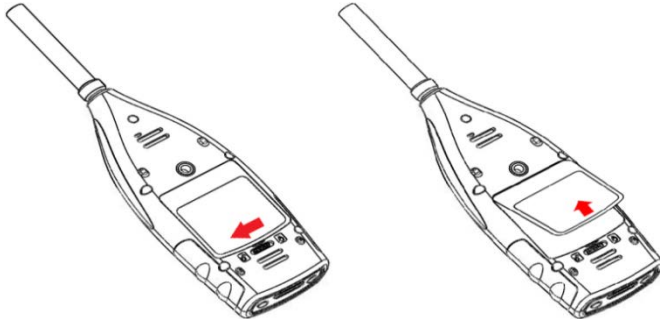

Turn the lock right to enable cover removal. Remove the cover from the battery container.

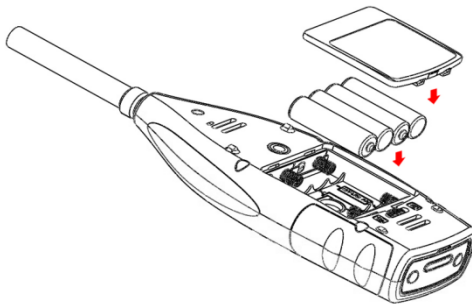

Replace the batteries and then close and lock the battery container cover.

## 2.6 GPS

GPS antenna located on top of the sound level meter with a GPS option.

**☆ Hint:** The user must know before shipment whether the GPS function is required, otherwise it will be necessary to return the sound level meter to the factory in order to install the GPS module.

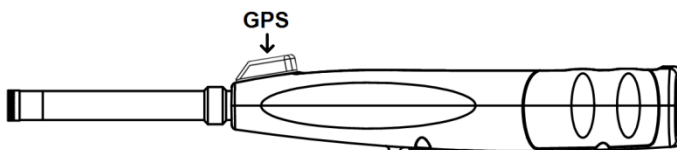

The GPS properties are influenced by two factors: satellite ephemerides and the signal-to-satellite noise ratio.

- **Satellite ephemerides:** Information on the GPS satellite orbit. Based on the ephemerides, satellite position signal and time, you can specify the current location. The satellite ephemerides should be downloaded from the GPS satellite, but the downloading speed is very low (approx. 50 bps) and depends on the satellite signal power. A high bit error rate may cause a longer or unsuccessful downloading of the ephemerides. Once the GPS module is deactivated, the sound level meter can store the ephemerides for approx. 30 minutes. The ephemerides remain valid for only 2 hours.
- **Signal-to-satellite noise ratio:** Power of satellite position signal. The signal power

is lower during rain or indoors.

The GPS mode has 3 start modes: cold start, warm start and hot start.

- The initial position determination, when the current ephemerides must be downloaded, requires more time.
- The GPS module stores the last location information data saved, but it requires another downloading of the ephemerides, as they are obsolete. The warm start requires almost the same time as the cold start.
- The GPS module includes the current ephemerides, so the position can be determined in a very short time.

### 3 Measurement screen

The sound level meter has two measuring modes: **Level Measurement** and **1/1 Octave Measurement**. The user can choose the type of measurement in the **Function** menu.

**The level measurement includes 8 screens that you can switch using the navigation keys <◀> i <▶>.** The 8 screens are: home, 3 profiles, LN statistics, time history, custom measurement 1, custom measurement 2, GPS 1 and GPS 2.

**The 1/1 octave measurement includes 4 screens:** octave bar chart and octave tables 1 to 3.

#### 3.1 Screen symbols and their meanings

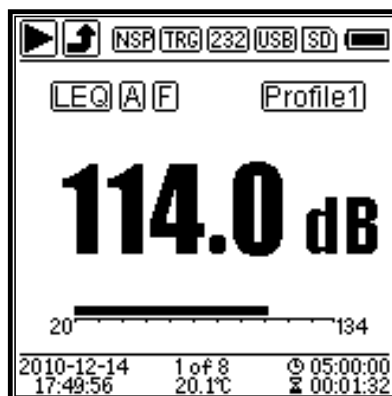

All the symbols on the home screen are active, their meanings are specified below:

	Start/Stop. Defines the measurement status.
	Overload or exceeding the lower range limit. If the arrow is displayed continuously, the current status is "Overload" or "Excess of lower range limit". The unfilled arrow indicates if the lower range limit was exceeded or the device was overloaded during integration. Upon starting a new integration period, the symbol of overload or excess of the lower range limit is deactivated.
	Status of ICCP module. It is shown when the ICCP module



	is deactivated.
	Trigger status. It is shown when the trigger is active.
	RS-232 interface status. The  symbol is shown in the <b>remote mode</b> , and the  symbol — in the printer mode.
	Timer status. The  symbol indicates that the timer is active and was activated only once. The  symbol indicates that the timer is active and will be activated again.
	Status of microSD memory. It is shown when the microSD memory is active.
	Switch-off status. The following symbols are shown, from left to right: external power supply, battery power supply (with voltage indicator), USB power supply.
	Measurement calculation mode.
	Filter status.
	Detector status.
	Profile symbol. Shows the profile number of the current indication.
	Measured value.
	Visualisation and displaying of measured values in the current measuring range as a dynamic bar indicator.
	Date and time.
	Current screen number and total number of screens.
	Ambient temperature indicator.
	The  symbol refers to the integration period, the  symbol shows the current time. The measurement will stop when the current time equals to the total measurement time (integration period * repetitions).

The symbols are displayed in such a sequence all the time. All the symbols can be seen on each screen and always have the same meaning.

### 3.2 Screen in the level measurement mode

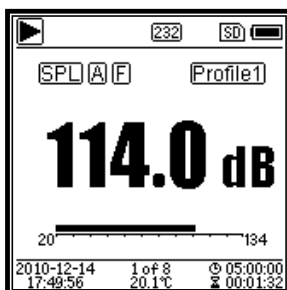

#### Home screen

Indication of measurement data, information on the filter, detector, mode and profile number. The home screen only shows the group of data from one of the 3 profiles. To switch between the 3 profiles, press the navigation keys **<▲>** and **<▼>** simultaneously.

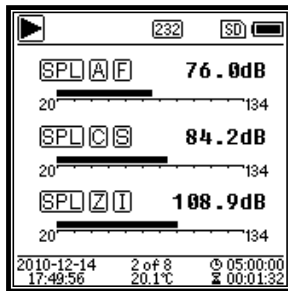

### 3 profiles

Indication of data and the relevant measurement mode, information on the filter and profiled measurement detector. The data of the 3 profiles can be saved in a single SWN file.

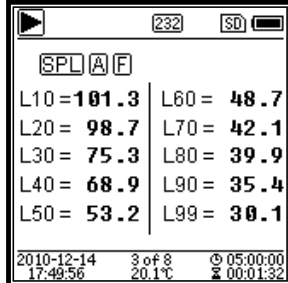

### LN statistics

Showing 10 groups of statistical results. Each group of data source can be adjusted (a fixed mode for SPL, filter and detector), and the percentage can be set in the menu.

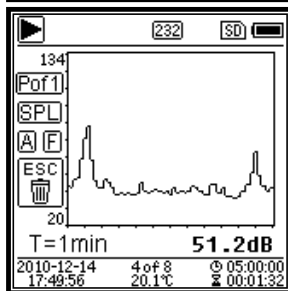

### Time history

Showing the current noise level and characteristics as a function of time. The data sources (one of 3 profiles) and time axis (1 minute, 2 minutes and 10 minutes) can be adjusted.

Press <ESC> to remove the characteristics from the screen and display it again.

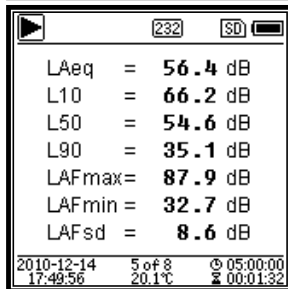

### Custom Measurement screen 1

The user can set the parameters for 14 measurement groups. Here you can display the first 7 measurement groups.

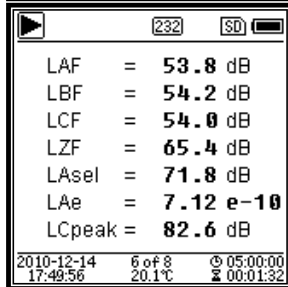

### Custom Measurement screen 2

The user can set the parameters for 14 measurement groups. Here you can display the last 7 measurement groups.



### GPS screen 1

Display of GPS information: GPS state, GPS date, GPS time, longitude, latitude, altitude and speed.

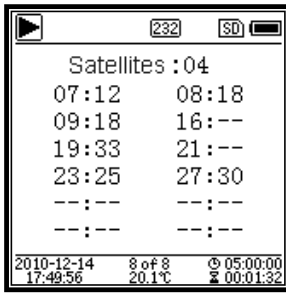

### GPS screen 2

Display of the number of satellites used to determine the position and the signal-to-noise ratio for all the visible satellites (0–99 dB).

**★Hint:** The number of visible satellites can be higher than the number of satellites used to determine the position, as many satellites are not available for position determination.

## 3.3 1/1 Octave Mode screen

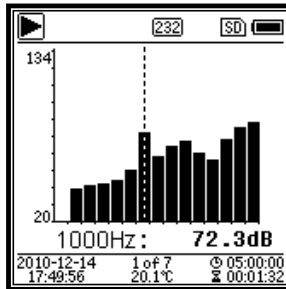

### 1/1 octave bar chart

Shows 10 bands in a range from 31.5 Hz to 16 kHz and the  $L_{Aeq}$ ,  $L_{Beq}$ ,  $L_{Ceq}$ ,  $L_{Zeq}$  parameters in the form of a bar chart. Press the navigation keys  $\blacktriangle$  and  $\blacktriangledown$  to see detailed values for each band. You can define a threshold value for each band. If the data exceed the threshold value, a red LED will light up.

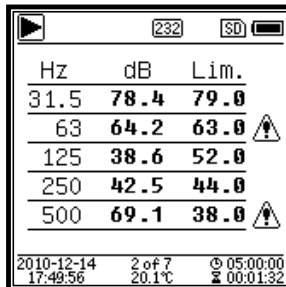

### Octave Table screen 1

Shows measurement data within a range from 31.5 Hz to 500 Hz. If the data exceed the threshold value, a red LED will light up and the  $\triangle$  symbol will appear.

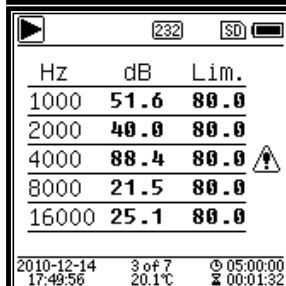

### Octave Table screen 2

Shows the measurement data within a range from 1 kHz to 16 kHz. If the data exceed the threshold, a red LED will light up and the  $\triangle$  symbol will appear.

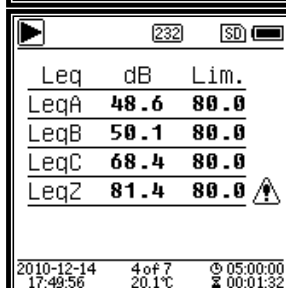

### Octave Table screen 3

Shows the measurement data of  $L_{Aeq}$ ,  $L_{Beq}$ ,  $L_{Ceq}$  and  $L_{Zeq}$ . If the data exceed the threshold value, a red LED will light up and the  $\triangle$  symbol will appear.

## 4. Operation and setting the menu



Press <MENU> to show the next menu. All the measurement parameters can be set in the menu.

### Menu tree

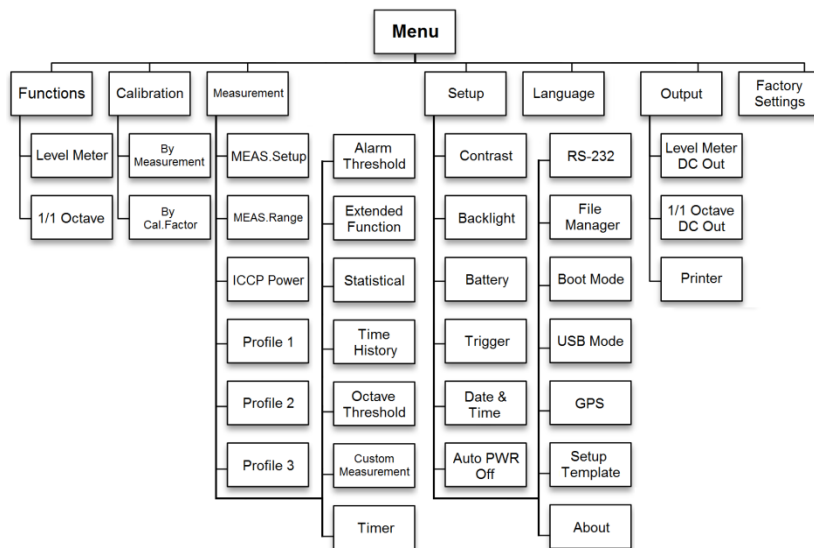

### 4.1 Function

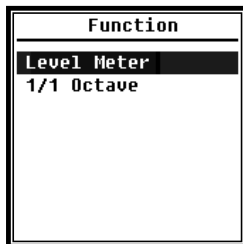

Select **Function** and press <ENTER> to open this menu. You can choose 2 types of measurement. **Level measurement** and **1/1-octave measurement**. Press the navigation keys <▲> and <▼> to choose the measurement mode. Press <ENTER> to save the setting and return to the previous menu. Press <ESC> to return to the previous menu.

### 4.2 Calibration

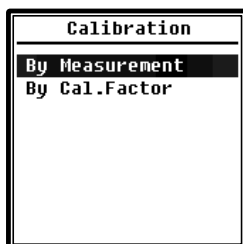

Select **Calibration** and press <ENTER> to open this menu.

The microphone sensitivity is influenced by many factors, such as temperature, humidity or air pressure. This is why you must perform at least one calibration before the measurement.

Two calibration methods are available. **By Measurement** and **By Calibration Factor**. Choose **By Measurement** to perform the calibration using the sound calibrator. Calibration **By Calibration Factor** allows the user to manually adapt the calibration factor.

#### 4.2.1 Calibration by measurement

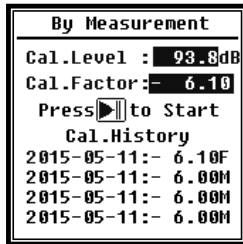

To open this menu, select **By Measurement** and press <ENTER>. Further details concerning the calibrator used and the appropriate adaptation value are provided in [Appendix 2, Adaptation of Control Calibration Frequency](#).

The calibration level can be adapted within a range from 0 dB to 199.9 dB. To change the calibration level, press the navigation keys <◀>, <▶>, <▲> and <▼>; to start the calibration, press <START>. After the calibration, a new calibration factor will be introduced and the user can save or ignore the result by pressing <ENTER> or <ESC>, respectively. Here you can also see the process of calibration. The entries with the letter **M** at the end indicate that the records have been calibrated **by measurement**.

#### 4.2.2 Calibration by calibration factor

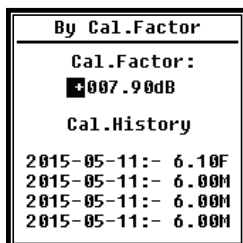

Select **By Calibration Factor** and press <ENTER> to open this menu.

You can adapt the calibration factor manually. Using the navigation keys <◀> and <▶>, you can choose the factor number, and using the navigation keys <▲> and <▼>, you can save the value by pressing <ENTER> and return to the previous menu by pressing <ESC>. The entry with the letter **F** at the end indicates that the record has been calibrated **by calibration factor**.

#### 4.2.3 Calculation of calibration factor and sensitivity

Sensitivity can be calculated using the following formulas. Based on sensitivity, you can also calculate the calibration factor and introduce it directly into the sound level.

$$\begin{aligned} \text{Cal.F} &= 20 * \log (\text{Sens} / 50) + \text{offset} \\ \text{Sens} &= 50 * 10^{((\text{Offset of the calibration factor}) / 20)} \end{aligned}$$

Where:

*Cal.F* = calibration factor in decibels (dB);

*Sens* = microphone sensitivity in mV/Pa;

*Offset* = offset of the calibration factor in decibels (dB). The value is a result of calibration **by measurement** and a 50 mV signal. The offset is an own deviation of the device, which differs depending on the sound level meter.

#### 4.2.4 Calibration by measurement

Calibration by measurement is the recommended method of calibration performed using a sound calibrator. KERN can supply Class 1 and 2 sound calibrators conformant to GB/T 15173-2010 and IEC 60942:2003.

Calibration by measurement is performed as follows:

- (1) Insert the microphone all the way into the calibrator cavity; it must be firmly settled.

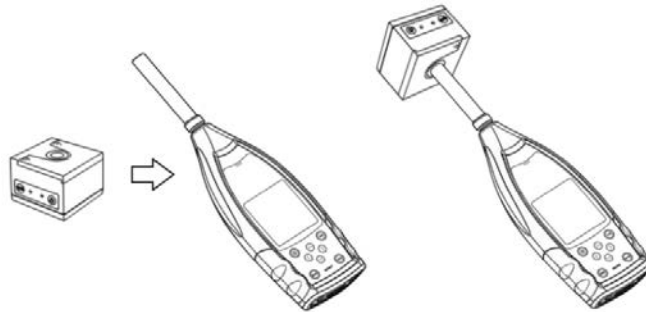

- (2) Switch on the calibrator and set a fixed sound level (e.g. 94 dB).

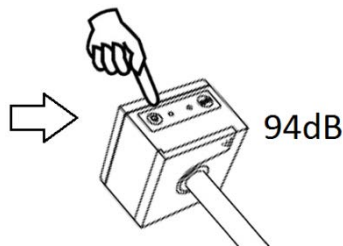

- (3) To open the **By Measurement** menu, select **Calibration** and press <ENTER>.

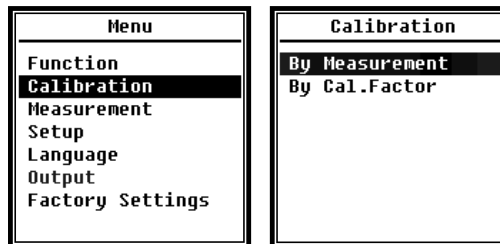

- (4) In the menu, set the **Cal.Level** value to e.g. 93.8 dB. The calibration process takes 5 s from pressing <START>.

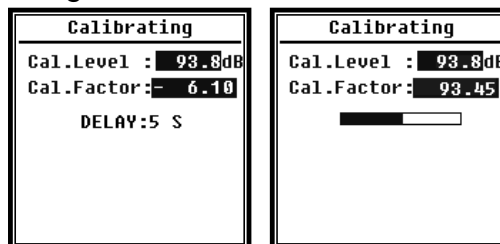

- (5) When it is completed, the calibration factor in the sound level meter will be updated. Press <ENTER> to apply the results.

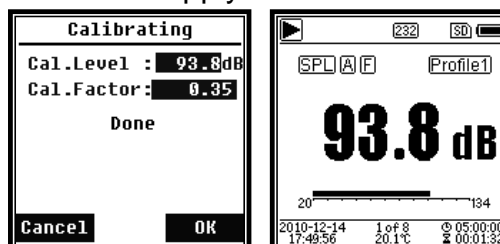

- (6) To start the measurement, open the **home screen** again and press **<START/STOP>**. If the calibrator works properly, for the example given in this manual the current measurement result is 93.8 dB.

### 4.3 Measurement

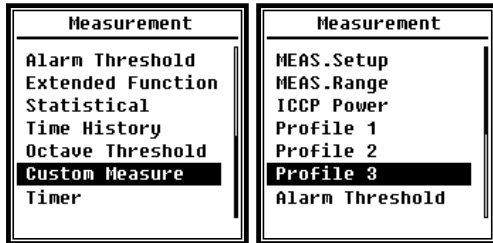

The **Measurement** menu includes 13 options. Using the navigation keys **<▲>** and **<▼>**, you can choose the options and open the next menu by pressing **<ENTER>**.

#### 4.3.1 Measurement setup

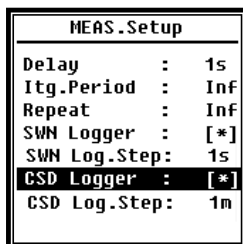

The **MEAS.Setup** menu is the most important for the measurement. Here you can set the following parameters: **Delay**, **Integration Period**, **Repeat**, **SW Log.Step**, **SWN Log.Step**, **CSD Logger** and **CSD Log.Step**. You can choose the options by pressing the navigation keys **<▲>** and **<▼>**.

##### ▷Delay:

Delay between pressing **<START>** and beginning the measurement. With the navigation keys **<◀>** and **<▶>**, you can choose the delay as follows: Sync 1 min, Sync 15 min, Sync 30 min, Sync 1 h, or 1 s to 60 s.

The delay prevents the influence on the measurement by vibration or key pressing.

##### ▷Itg.Period:

**Itg.Period** is the integration period for each individual measurement. At the beginning of each integration period, the integration and time data are reset, and the indication of overload or exceeding the lower range limit is deleted. The integration and time data are: LEQ, Max, Min, Peak, SD, SEL, E and LN. With the **<◀>** and **<▶>**, you can select the following options: indefinite, 1 s to 59 s, 1 min to 59 min, 1 h to 24 h.

##### ▷Repeat:

The number of measurement repetitions. Total measurement time = **Itg.Period** × **Repeat**. With the **<◀>** and **<▶>** keys, you can choose the following options: Inf, 1~9999.

##### ▷SWN Logger:

Press the navigation keys **<◀>** and **<▶>** to switch. If you choose this option, the sound level meter will save the data as SWN/OCT files.

The SWN/OCT files are used to save the time history data. The data source in the **sound level meter mode** is the profile 1–3 (select profile 1–3 in “SWN Save”); the data are saved as an SWN file. In the 1/1-octave mode, all the oc-

tave bands and the parameters LAeq, LBeq, LCEq, LZeq are saved as an OCT file.

▷ **SWN-Log.Step:**

**SWN-Log.Step** is a logging step (step period) used to save the data as SWN/OCT files. With the <◀> and <▶> keys, you can choose the following options: 0.1 s, 0.2 s, 0.5 s, 1 s to 59 s, 1 min to 59 min, 1 h to 24 h.

▷ **CSD Logger:**

Press the navigation keys <◀> and <▶> to switch. By choosing the relevant option, the sound level meter saves the results as CSD files.

The CSD files are used to save instantaneous data. The data source in the **sound level meter mode** are 14 group results of **custom measurement**; they are saved as a CSD file. In the 1/1-octave mode, all the octave bands and the parameters LAeq, LBeq, LCEq, LZeq are saved as a CSD file.

★ **Hint:** To save the data as a CSD file manually, after the measurement is stopped select the relevant option and press <ENTER> on the home screen.

▷ **CSD Log.Step:**

**CSD-Log.Step** is a logging step (step period) used to save the data as CSD files. With the <◀> and <▶>, you can select the following options: 1 s to 59 s, 1 min to 59 min, 1 h to 24 h.

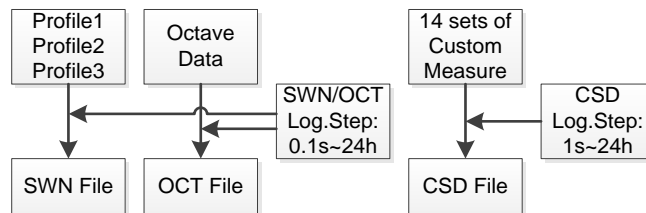

★ **Hint:** The SWN/OCT files can only be used to save the integration data. The logging step can be regarded as the integration period. All the data within the logging step (integration period) are saved as an SWN/OCT file in a single line. The CSD files are only used to save instantaneous data, without integration. Immediately after the CSD logging step is completed, the data from 14 sets of custom measurement are saved in a line of a CSD file as a snapshot.

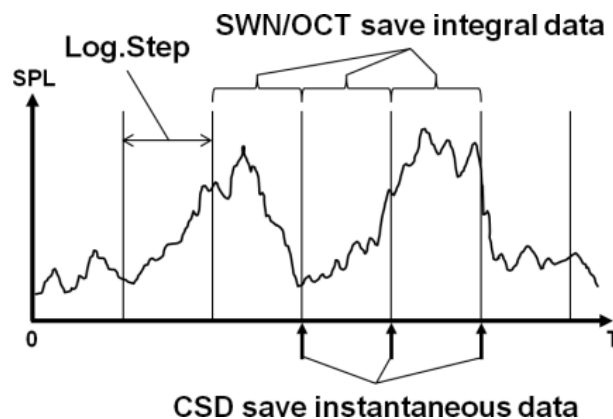



### 4.3.2 Measuring range

MEAS.Range
Linearity Range: 20.0dBA - 134.0dBA
Dynamic Range: 11.0dBA - 134.0dBA
Peak C Range: 45.0dBA - 137.0dBA

The **MEAS.Range** includes the **Linearity Range**, **Dynamic Range** and **Peak C Range**.

With the new algorithm, there is only one measuring range, so switching between the ranges is not required. The algorithm meets the requirements of a pulse frequency response of up to 0.25 ms with an error being as low as 0.1 dB at 4 kHz. At a pulse sequence of 0.125 ms and frequency of 4 kHz, the error is 0.4 dB.

▷**Linearity Range:** The measurement result can be considered correct only if it remains within the linearity range. Otherwise the measurement result error exceed the tolerance limit. Sometimes the linearity range is called the “measuring range”.

▷**Dynamic Range:** The dynamic range is a range between the own noise and the maximum input signal level. The dynamic range is the maximum range that the sound level meter can display. A result close to the own noise cannot be treated as a linear result.

▷**Peak C Range:** The Peak C Range is a linear Peak C measuring range. The Peak C measurement within this range can be considered to be correct.

### 4.3.3 ICCP Power

ICCP Power
ICCP Power : <b>ON</b>

In the ICCP menu, you can adjust the power supply for all ICCP sensors using a DC power source of 24 V/4 mA. The ICCP power should be deactivated before connecting another sensor or before a direct connection to the signal source. Press the navigation keys <◀> and <▶> to choose an option.

### 4.3.4 Profiles 1– 3

Profile 1
Filter : <b>A</b>
Detector : Fast
Mode : SPL
SWN Save : LEQ

The Profiles 1–3 menu allows you to define the filter, detector, mode and options for SWN file storage. You can choose the options by pressing the navigation keys <▲> and <▼>.

▷**Filter:**

You must define the filter for Profiles 1–3. With the <◀> and <▶> keys, you can choose the following options: **A**, **B**, **C** and **Z** (Z correction) means “no correction”. It is sometimes called the “fixed correction” or “linear correction”.

▷**Detector:**

You must define the filter for Profiles 1–3. With the <◀> and <▶> keys, you can choose the following options: **Fast**, **Slow** and **Pulse**.

▷**Mode:**

It defines the integration mode for Profiles 1–3. With the <◀> and <▶> keys, you can choose the following options: **SPL**, **PEAK**, **LEQ**, **MAX** and **MIN**.

▷**SWN Save:**

With this option, you can define the data to be saved as an SWN file, since their source is the SWN file for Profiles 1–3. This option is not represented on the

screen. With the <◀> and <▶> keys, you can choose the following options: **LEQ**, **PEAK**, **MAX** or **MIN**.

#### 4.3.5 Alarm Threshold



If the measurement results for Profiles 1–3 exceed the **Alarm Threshold**, the red LED above the <POWER> key will light up. The alarm threshold can be set within a range from 20 dB to 200 dB. With the navigation keys <▲> and <▼>, you can increase or reduce the alarm threshold by 1 dB. With the navigation keys <◀> and <▶>, you can increase or reduce the setting by 10 dB.

#### 4.3.6 Extended Function

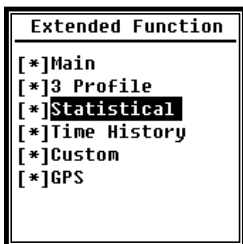

The extended function allows you to choose the screen to be shown. If the screen is not selected, it will not be displayed. Note that the **Main** menu screen is always shown.

#### 4.3.7 Statistical

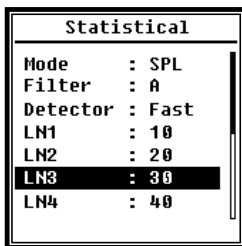
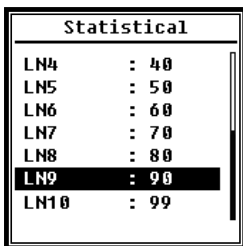

A fixed data source set for statistical purposes is the SPL. The user cannot change this setting. However, in this menu the user can define the SPL detector and filter as well as the statistical value.

##### ▷Mode:

The SPL settings is fixed and cannot be changed.

##### ▷Filter:

By pressing the navigation keys <◀> and <▶>, you can define the filter for statistical analysis: **A**, **B**, **C** and **Z** (linear).

##### ▷Detector:

By pressing the navigation keys <◀> and <▶>, you can set the detector for statistical analysis: **Fast**, **Slow** and **Pulse**

##### ▷LN1 to LN10:

By pressing the navigation keys <◀> and <▶>, you can defined the percentage of 10 LN groups within a range from 1% to 99%.

Example: **LN1:10 = 80 dB** means that in the integration period 10% of measurement data are above 80 dB. The LN result depends on the integration period. With the beginning of a new integration period, the result is reset.

### 4.3.8 Time History



With the navigation keys <▲> and <▼>, you can set the data source and duration of the time history.

▷**Profile:**

With the navigation keys <◀> and <▶>, you can set the data source for the time history: **Profile 1, Profile 2, Profile 3.**

▷**Duration:**

With the navigation keys <◀> and <▶>, you can set the time axis for the time history. **1 minute, 2 minutes, 10 minutes.**

### 4.3.9 Octave Threshold

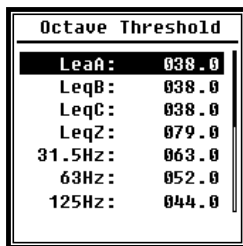
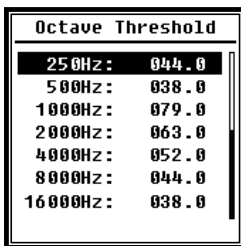

In the **Octave Threshold** menu, you can set the alarm threshold within a range from 31.5 Hz to 16 kHz as well as parameters LAeq, LBeq, LCeq and LZeq. If the measurement result exceeds the threshold, a red LED will light up. By pressing the navigation keys <◀> and <▶>, you can set the options within a range from 0.1 dB to 199.9 dB.

### 4.3.10 Custom Measure

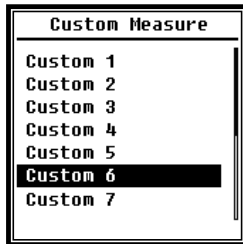
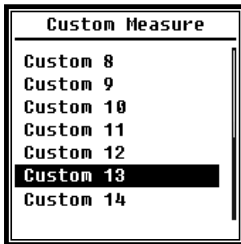

The **Custom Measure** menu offers 14 options where you can define the parameters for 1–14 custom measurements. With the navigation keys <▲> and <▼>, you can choose the option and open the next menu level by pressing <ENTER>.

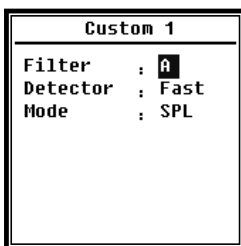

With the navigation keys <▲> and <▼>, for each group of measurements you can set the option: **Filter, Detector and Mode.**

▷**Filter:**

With the navigation keys <◀> and <▶>, you can set the filter for custom measurements: **A, B, C** and **Z** (linear).

▷**Detector:**

With the navigation keys <◀> and <▶>, you can set the detector for custom measurements: **Fast, Slow** and **Pulse**

▷**Mode:**

With the navigation keys <◀> and <▶>, you can set the integration mode for custom measurements: **SPL, SD, SEL, E, Max, Min, Peak, LEQ, LN1 to LN10.**

### 4.3.11 Timer



In the timer menu, the **Timer** option allows you to set the **Start Day**, **Start Time** and **Repeat Interval**. Press the navigation keys <▲> and <▼> to choose the option.

To enable a programmed start of measurement, we introduced a new function called **Timer**. To perform an automatic measurement for 24 hours, you can set the device as follows: measurement start on the next day at 00:00, measuring for several minutes and repeating the measurements every hour.

▷**Timer:**

By pressing the navigation keys <▲> and <▼>, you can set the **Timer** operating mode: **OFF**, **One Time** and **Loop**.

▷**Start Day:**

By pressing the navigation keys <▲> and <▼>, you can set the **Timer** trigger start date: **Ignore** and a fixed day every 30 days. If you choose **Ignore**, the **Timer** ignores the date, and the timer is released using only the **Start Time**.

▷**Start Time:**

By pressing the navigation keys <▲> and <▼>, you can set the **Timer** start time: **00:00~23:59**.

▷**Repeat Period:**

After releasing the **Timer**, it will be released again upon the expiry of the **repeat period**. With the <◀> and <▶> keys, you can choose the following options: **1 min~59 min, 1 h~24 h**.

☆ **Hint:** The **repeat period** must be longer than the total integration period (**Integration Period** × **Repeat**) plus 5 s, since the fixed delay of the **timer** with an activated measurement is set to 3 s, and before another delay of 2 s is required. Do not change the setting when the **timer** is operating. Otherwise the **timer** will get damaged.

#### 4.3.12 24 h Measurement with Timer

Using the **timer**, you can implement a 24 h measurement. The description below presents an example of a 24 h measurement implementation.

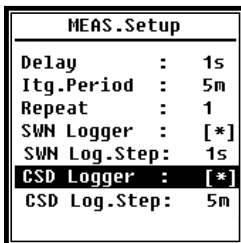

Purpose: The measurement starts on 14 March 2015 at 00:00 and is repeated every hour for 5 minutes. When the measurements stop, the measured values are saved as CSD, and each second is saved as SWN.

If the timer releases the measurement, the delay set in the MEAS.Setup menu will be ignored. The **Itg.Period** should be set to **5 min** and **Repeat** should be set to **1**. Then you should activate the SWN and CSD loggers. The SWN logging step should be set to 1 s and the CSD logging step — to 5 min.

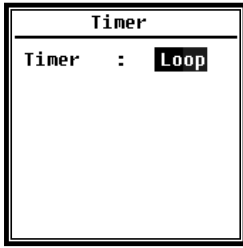

In order to always restart the measurement, set the **Timer** to **Loop**.  
Set the required date as the **Start Day**.

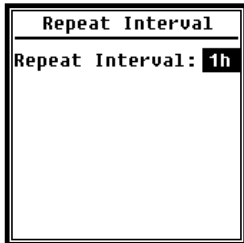

Set the **Start Time** to **00:00**. This is the time when the measurement will be initially activated. In order for the measurement to be reactivated every hour, set **Repeat Interval** to **1 h**.

#### 4.4 Setup



The **Setup** menu allows you to set the main function and conditional display. With the navigation keys **<▲>** and **<▼>**, you can choose the option and open the next menu level by pressing **<ENTER>**.

##### 4.4.1 Contrast

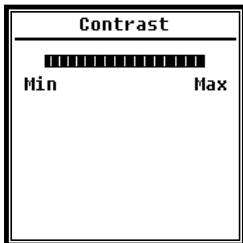

The **Contrast** menu allows you to set 14 contrast levels of the LCD display. Press the navigation keys **<▲>** and **<▼>** to choose the option.

##### 4.4.2 Backlight

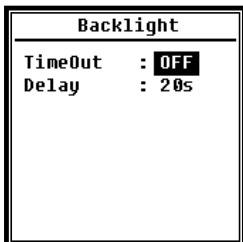

The backlight of the sound level meter is automatically switched off to reduce power consumption and to save the batteries. In the **Backlight** menu, you can activate or deactivate the automatic switch-off and change the backlight delay. Press the navigation keys **<▲>** and **<▼>** to choose the option.

##### 4.4.3 Battery

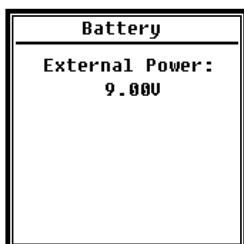
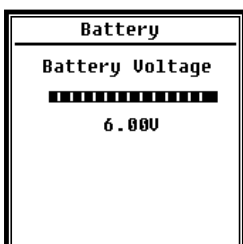

The **Battery** menu shows the battery status and voltage. The final voltage of a single LR6/AA/AM3 battery cell is approx. 0.9 V, so the sound level meter is automatically switched off when the total voltage at 4 cells of the alkaline battery drops below 3.6 V.

#### 4.4.4 Trigger

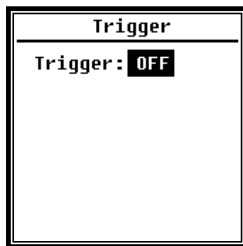

The **Trigger** menu allows you to activate or deactivate the trigger function. **Trigger** is the analogue input which, using remote control commands, enables starting or stopping a measurement performed with the sound level meter. The trigger input is located in at the bottom of the meter (3.5 mm headphone port).

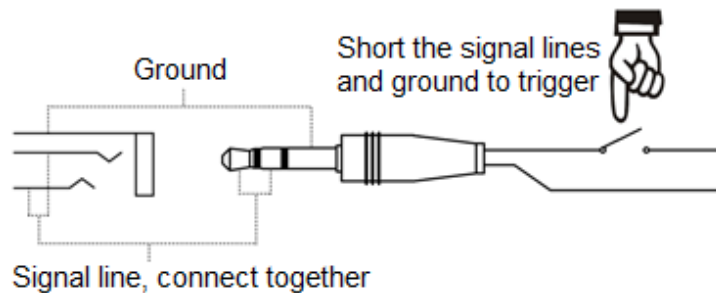

The measurement starts after connecting a signal cable to ground and stops upon disconnection. Note that when the **Trigger** function is active, the **<START/STOP>** key is unavailable.

#### 4.4.5 Date & Time



The **Date & Time** menu allows you to set the time of the real-time clock (RTC) installed in the sound level meter. Press the navigation keys **<▲>** and **<▼>** to choose the option.

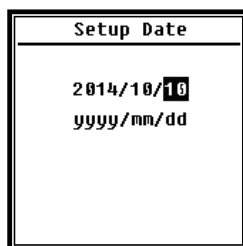
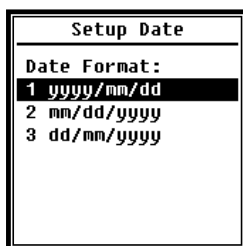

By pressing the navigation keys **<▲>** and **<▼>**, you can choose the date format or change the date. By pressing the navigation keys **<◀>** and **<▶>**, you can choose the year, month and day, and with the navigation keys **<▲>** and **<▼>**, you can modify their values. Press

**<ENTER>** to save the setting.

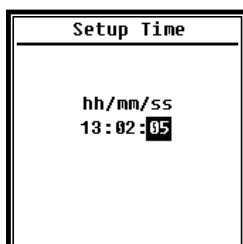

Follow the same procedure to change the time setting. By pressing the navigation keys **<◀>** and **<▶>**, you can choose the hour, minute and second, and with the navigation keys **<▲>** and **<▼>**, you can modify their values. Press **<ENTER>** to save the setting.

The RTC is powered by an internal buffer battery. The RTC battery should be changed if the date and time shown on the sound level meter is incorrect due to a low voltage of the RTC battery. Advice on the change of RTC battery: To remove the cover, unscrew the 5 bolts located at the rear of the sound level meter. The RTC battery is located on the plate, as shown in the figure. The battery has the form of a CR-1220 button cell.

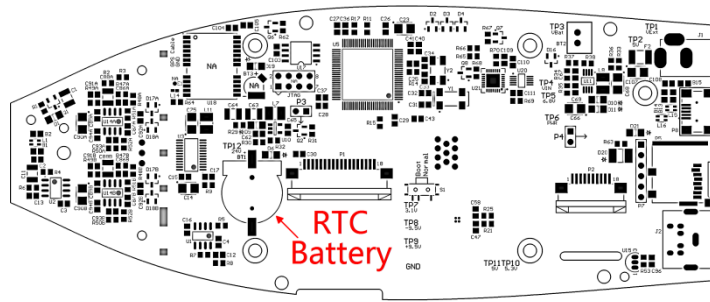

☆ **Hint:** The system clock installed in the sound level meter was calibrated using a reference clock with an average error of 2 ppm (maximum error: 3 ppm). The time accuracy at room temperature is below 10 ppm (< 26 s in 30 days). The maximum time error during internal tests at 25°C was approx 5–8 s.

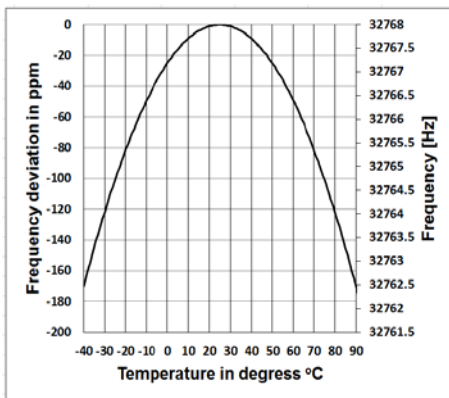

The system clock accuracy may vary depending on the temperature due to the lack of temperature compensation. At the typical characteristics shown in the figure, the basic frequency of the system clock remained unchanged. Any increase or decrease of temperature causes a change in the system clock frequency by approx.  $-0.04 \text{ ppm}/^\circ\text{C}^2$ . Therefore, when the temperature is  $0^\circ\text{C}$ , the value for the system clock changes by  $-0.04 \times (0-25)^2 = -25 \text{ ppm}$ , which corresponds to a delay of

approx. 2.16 s per day. If the temperature is  $40^\circ\text{C}$ , the value for the system clock changes by  $-0.04 \times (40-25)^2 = -9 \text{ ppm}$ , which corresponds to a delay of approx. 0.78 s per day.

The maximum error (< 10 ppm) specified in the User Manual, can be calculated as approx.  $16^\circ\text{C}$  of difference compared to the reference temperature of  $25^\circ\text{C}$ . Therefore, the RTC error within 30 days at a temperature of  $9^\circ\text{C}$  to  $41^\circ\text{C}$ , i.e. ambient temperature, can be maintained at 26 s. If the temperature range is exceeded, the actual RTC error may be higher than the value specified in the User Manual.

#### 4.4.6 Auto Power Off

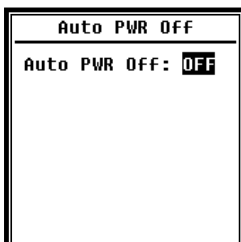

The sound level meter is provided with the Auto Power Off function, activated upon a drop of current consumption. If the sound level meter remains in the Stop mode and no key is pressed for a specific time, the device will switch off as per this setting. The Auto Power Off function offers the following settings: **1 minute**, **5 minutes**, **10 minutes**, **30 minutes**, **OFF** Press the navigation keys <◀> and <▶> to choose an option. Press <ENTER> to save the setting.

### 4.4.7 RS-232

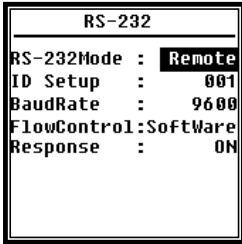

The RS-232 menu allows to set a serial port option, see section 5 RS-232 Data Exchange Protocol.

▷ **RS-232 Mode:**

**RS-232 options: Remote, Printer.** Press the navigation keys <◀> and <▶> to choose an option. In the **Remote** mode, the RS-232 port provided in the sound level meter enables control and data transmission. In the **Printer** mode, the RS-232 interface allows to connect a thermal printer (option).

▷ **ID Setup:**

In the **ID Setup** menu (further information, see [5.2.2 Device ID](#)), you can set an ID number which allows you to differentiate between several sound level meters connected to the network. The ID can be set within a range from 1 to 255. Press the navigation keys <◀> and <▶> to choose an option.

▷ **BaudRate:**

The **BaudRate** (further information, see [5.1 Hardware Configuration and Interface Settings](#)) determines the rate of data transmission by RS-232: **4,800 bps, 9,600 bps, 19,200 bps**. Press the navigation keys <◀> and <▶> to choose an option.

▷ **The following options are available:**

**FlowControl:** (See [5.2.7. Flow control](#)). The flow control allows you to set the data flow mode at remote operation. Options: **Software, Programme**. Press the navigation keys <◀> and <▶> to choose an option.

▷ **Response:**

**Response** (further information, see [5.3 Instructions](#)). It allows activation or deactivation of the response signal (ACK/NAK). Options: **ON, OFF** Press the navigation keys <◀> and <▶> to choose an option.

### 4.4.8 File Manager

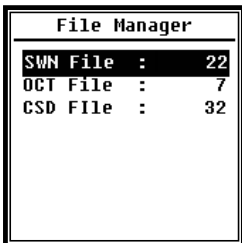

The **File Manager** allows you to manage the saved SWN, OCT and CSD files. The figures given in each line on the right indicates the number of files of each type. With the navigation keys <▲> and <▼>, you can choose the option and open the next menu level by pressing <ENTER>.

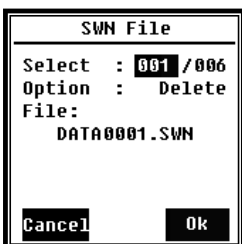

In the **SWN File** menu, you can delete the SWN files using the navigation keys <▲> and <▼>. Select the number of the file to be deleted. You will see the file number at the bottom edge of the screen. If you enter 0000 as the file number, you will delete all the available SWN files.



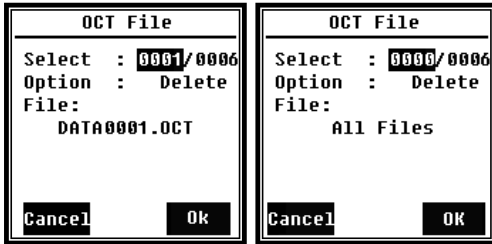

In the **OCT File** menu, you can delete the OCT file. The procedure is the same as for the **SWN File**.



In the **CSD File** menu, you can delete, display or print the content of the CSD file. By pressing the navigation keys **<▲>** and **<▼>**, you can move the cursor between **Select** and **Option**. The deletion procedure is the same as for the **SWN File**.

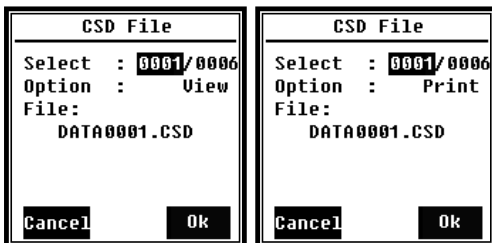

To display or print the content of the CSD file, select **Option** in the **CSD File** menu and press the navigation keys **<◀>** and **<▶>**.

To display or print the file content, select the file number and operation, and then press **<ENTER>**.

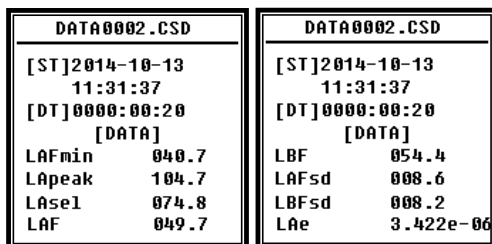

With the navigation keys **<▲>**, **<▼>**, **<◀>** and **<▶>**, you can view the file content in the **View** mode. The **Print** mode is almost identical to the **View** mode. Press **<Enter>** to print the content of the currently displayed CSD file.

#### 4.4.9 Boot Mode

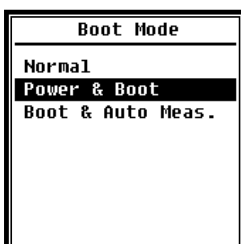

With the navigation keys **<▲>** and **<▼>** in the **Boot Mode** menu, you can select the modes: **Normal**, **Power & Boot** or **Boot & Auto Meas..**

☆ **Hint:** The hardware mode switch located in the battery container should be set accordingly to the boot mode.

##### ▷Normal:

The hardware mode switch should be set to **Normal**. This is the normal operating mode of the sound level meter.

##### ▷Power & Boot:

In this case, the hardware mode switch should be set to **Boot**. When you select this mode, the sound level meter will boot after power supply is detected. The

device can be integrated with another system, especially if there is a risk of power outage. In case of operating voltage loss, the sound level meter will automatically restart.

#### ▷ **Boot & Auto Meas.:**

In this case, the hardware mode switch should be set to **Boot**. Once this mode is selected, not only the sound level meter will boot upon the supply of operating voltage, but the device will also start measuring. After integrating the sound level meter with another system, upon a loss of operating voltage the device will boot and start the measurement.

#### ▷ **Hardware Mode Switch:**

The hardware mode switch is located in the battery container. It can easily be accessed after removing the batteries. The switch should be moved with pliers or a pencil to the “Boot” or “Normal” position.

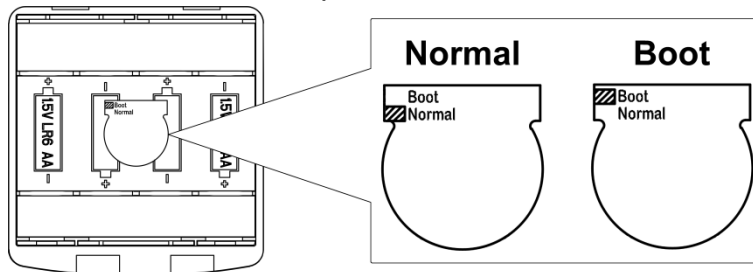

☆ **Hint:** This area is sensitive to electrostatic loads. Eliminate any electrostatic loads before handling.

#### 4.4.10 USB Mode



In the **USB Mode** menu, you can set the operating mode of the sound level meter connected to a computer using a USB cable. The following options are available: **Always Ask**, **USB Disk Mode** and **Modem Mode**.

#### ▷ **Always Ask:**

When you connect the device to a computer using a USB cable, you will always be asked about the mode. You should choose an option in due time, otherwise the computer will not be able to detect the sound level meter due to the excess of time.

#### ▷ **USB Disk Mode:**

The device always operates in the **USB Disk Mode**, so the question will not be shown when connecting it to a computer using a USB cable. The sound level meter can be detected by the computer as an exchangeable USB drive without the need to install a driver. You can directly access the files stored in the microSD card using Windows Explorer.

### ▷ Modem Mode:

In this case, after the device is connected to a computer using a USB cable, it will always operate in the **Modem Mode** without showing the question. The sound level meter can be detected by the computer as a serial (virtual) port using the same protocol as RS-232 interface (further details, see section 5. RS-232 Data Exchange Protocol).

#### 4.4.11 GPS



In the **GPS** menu, you can activate and deactivate the **GPS** and **Auto Time Sync** options. If **GPS** is deactivated, the internal GPS module is off. Upon activation of **Auto Time Sync**, the system clock installed in the sound level meter is synchronised with the GPS time.

#### 4.4.12 Setup Template

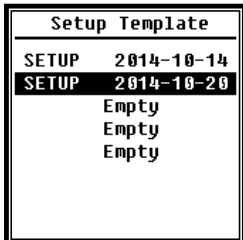

The “Setup Template” menu allows you to save five parameters of user group settings for different applications of the sound level meter.

☆ **Hint:** The template does not affect the calibration factor. Do not try to upload the old version of the template into the new version of firmware, as there might be some modifications.

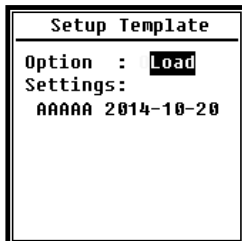

If the template is empty, press **<ENTER>**. The template allows to save the group settings whose description can be defined by the user with five letters or digits.

Press **<ENTER>** to upload or delete the present template.

#### 4.4.13 About

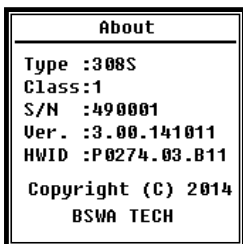

In the “About” menu, you can see the following information: type, class, serial number, version and HWID (hardware ID) of the sound level meter.

#### 4.5 Language



The sound level meter supports six languages: **English, Chinese, Portuguese, Spanish, German** and **French**. With the navigation keys **<▲>** and **<▼>**, you can select the language and confirm by pressing **<ENTER>**.

## 4.6 Output



The **Output** menu allows you to choose the measurement data sent to the **DC OUT**. For the **level meter** and **1/1-octave** modes, the options specify the DC output of the level meter and the 1/1-octave DC output.

The menu also offers the **Printer** option. Press the navigation keys **<▲>** and **<▼>** to choose the option.

### 4.6.1 AC OUT

The sound level meter is provided with two analogue outputs: **DC OUT** and **AC OUT**. The **DC OUT** or **AC OUT** should be connected to another device or system using the concentric cable. The input resistance of the terminal device or system should be approx. 5 kΩ.

The **AC OUT** port is located at the bottom of the sound level meter. The microphone signal is sent directly, without the possibility of adjustment. Maximum output voltage is 5 V<sub>eff</sub> ( $\pm 7$  V<sub>peak</sub>), maximum output current is  $\pm 15$  mA.

**☆ Hint:** If the input resistance of the terminal device or system is not sufficient, use an adapting system with impedance characteristics. The **AC OUT** can only be used to record the own noise or monitor the values below the lower limit of the meter's linear measuring range.

### 4.6.2 DC OUT

The **DC OUT** is used to send an analogue DC signal being proportional to the measurement result at a ratio of 10 mV/dB. For instance, if the result is 93.8 dB, the output supplies a voltage of 938 mV. This option is recommended for filtering or creating the average value of output signal to dampen the noise.

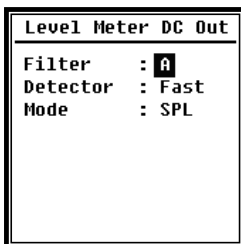

The **Level Meter DC Out** can be set as signal output for the level meter mode. Press the navigation keys **<▲>**, **<▼>**, **<◀>** and **<▶>** to choose an option.

**Filter:** A, B, C and Z (flat)

**Detector:** Fast, Slow, Pulse

**Mode:** SPL, LEQ, Peak

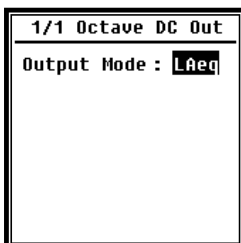

**1/1 Octave DC Out** defines the output signal in the 1/1-octave mode. The following options are available: LAeq, LBeq, LCeq, LZeq, 31.5 Hz, 63 Hz, 125 Hz, 250 Hz, 500 Hz, 1 kHz, 2 kHz, 4 kHz, 8 kHz, 16 kHz. Press the navigation keys **<◀>** and **<▶>** to choose an option.

### 4.6.3 Printer

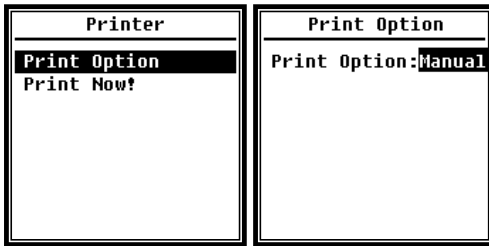

The **Print** option allows to set the automatic or manual printing mode. If you choose **Auto**, the measurement results will be printed automatically once the measurement is stopped.

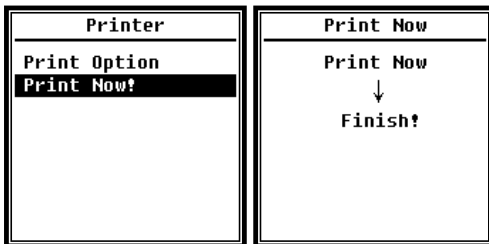

If you choose **Manual**, you will have to click **Print Now** and press **<ENTER>** to print the measurement results.

**☆ Hint:** Before printing, change the **Printer** mode in the **RS-232** menu.

### 4.7 Factory Settings

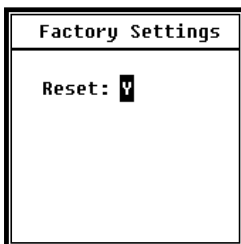

The **Factory Settings** menu allows you to reset all the parameters previously changed by the user and restore the factory settings. The parameters will be initiated with the standard values. By pressing the navigation keys **<◀>** and **<▶>**, you can choose **Y** (Yes) or **N** (No). The parameters will be initiated after selecting **Y** (Yes) and pressing **<ENTER>**. By selecting **N** (No) or pressing **ESC**, you will cancel the resetting process.

## 5. RS-232 Data Transmission Protocol

The **SW 1000/200** sound level meter is supplied with RS-232 serial interface. Using the serial interface, you can modify the settings of the sound level meter, start and stop the device, send a query about the current values of measurement parameters or process the results. The operation using the serial interface is the same as the operation using the keyboard.

### 5.1 Hardware configuration and interface settings

The **SW 1000/200** uses a 3-core serial interface, and the physical port is a 6-pin PS/2 socket. The definition of RS-232 is presented below:

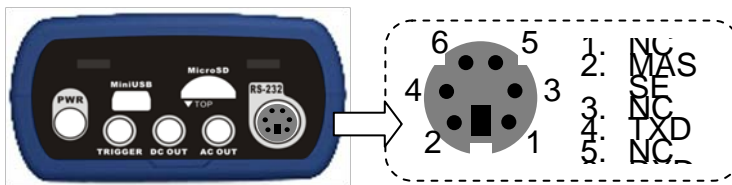

Transmission settings for RS-232 interface:

Transmission mode	full duplex
Synchronous/asynchronous mode	asynchronous transmission
Baud rate	4,800 bps, 9,600 bps, 19,200 bps
Data bits	8 bits
Stop bits	1 bit
Parity	none
Flow control	include the time data specified in the table with nominal parameters

### 5.2 Transmission protocol

The RS-232 interface protocol used in **SW 1000/200** is based on a block transmission corresponding to the following pattern:

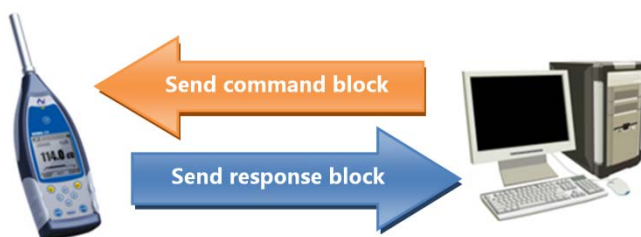

A typical command block or response block consists of a start-of-text character, identifier (ID), attribute character, command or data, end-of-text character, block check character, line feed character and carriage return character, as per the diagram below:

<STX>	ID	ATTR	Command or data	<ETX>	BCC	<CR>	<LF>
-------	----	------	-----------------	-------	-----	------	------

### 5.2.1 Beginning and end of block transmission

The command or response block contains a start character, end character and other control characters described in the table below:

Name	Value in hexadecimal system	Meaning
<STX>	02H	Start of text
<ETX>	03H	End of text
<CR>	0DH	Carriage return
<LF>	0AH	Line feed

### 5.2.2 Device ID

Each command block contains an identifier (ID). It is used to differentiate several sound level meters connected to a single network. After receiving a command block, the sound level meter compares the command block ID with its own ID. The appropriate operation will be performed if both IDs are identical. Otherwise the command will be ignored. The response block sent by the sound level meter also includes an ID which defines the location from which the block was sent.

**☆ Hint:** Make sure that the IDs of sound level meters connected to the same network are different, otherwise the operation will be disturbed!

The ID is a single binary address byte. It ranges from 1 to 255, which corresponds to the hexadecimal system values from 01H to FFH.

If the ID contained in a command block is 00H, it means a broadcast command. In case of a broadcast command, the sound level meter executes the instruction regardless of its own ID, without sending back the data.

Name	Value in hexadecimal system	Meaning
ID	01H to FFH	Device ID
	00H	Broadcast command

### 5.2.3 Attribute character (ATTR)

The ATTR character determines the type of command or response.

Name	Value in hexadecimal system	Meaning
'C'	43H	Command block
'A'	41H	Response block
<ACK>	06H	Acknowledge
<NAK>	15H	Negative acknowledge

### 5.2.4 Block check character (BCC)

The BCC character in a block is calculated by the transmitter. Then the BCC value is calculated by the receiver and compared to the BCC value in the transmitter block. The received block is correct if both values are identical. The BCC value is calculated from the bytes between <STX> and <ETX> characters using XOR operation. If the

BCC value is 00H, the sound level meter does not check the data, and the authorised instruction is processed directly. This way you can simplify the transmission of an instruction block, but this method is not recommended for long-distance transmissions, as the BCC value is the only possibility to ensure the reliability of data transmission.

Name	Value in hexadecimal system	Meaning
BCC	01H to FFH	XOR checksum
	00H	Ignore the checksum

### 5.2.5 Block transmission format

There are four possible types of block transmission of data: command block, response block, acknowledge block and negative-acknowledge block. The four types of formats and instructions are specified below:

#### (1) Command block: sent by the computer

<STX>	ID	ATTR	Instruction	Parameters	<ETX>	BCC	<CR>	<LF>
1	1	1	3	N	1	1	1	1 byte

Where: ATTR = 'C'.

All instructions take 3 bytes. If a block contains more than one parameter, all the parameters must be separated with a space.

#### (2) Response block: sent by the sound level meter

<STX>	ID	ATTR	Response	<ETX>	BCC	<CR>	<LF>
1	1	1	N	1	1	1	1 byte

Where: ATTR = 'A'.

If a block contains several response data, all the data must be separated by a comma (,).

#### (3) Acknowledge: sent by the sound level meter

<STX>	ID	ATTR	<ETX>	BCC	<CR>	<LF>
1	1	1	1	1	1	1 byte

Where: ATTR = <ACK>.

#### (4) Negative acknowledge: sent by the sound level meter

<STX>	ID	ATTR	Error code	<ETX>	BCC	<CR>	<LF>
1	1	1	4	1	1	1	1 byte

Where: ATTR = <NAK>.

The error code takes 4 bytes. All the possible error codes are listed in the table below. Meaning of error codes, see section [5.2.6](#).

Error code	Meaning
0001H	Instruction error
0002H	Parameter error
0003H	Unavailable under the current status



## 5.2.6 Restoration after transmission errors

Various errors can occur during a transmission of command block or response block. Below we present the manner in which the sound level meter treats the errors and restores the original status.

### (1) Incomplete block transmission

The four block transmission formats are specified in section [5.2.5](#). Immediately after detecting an <STX> character block, the sound level meter receives subsequent data until the <CR> and <LF> characters appear. When the data reception is complete and the parity is correct, the sound level meter performs a final check. If the <STX> character is received again before <CR> and <LF>, the sound level meter ignores all the information received before and begins the block reception.

### (2) Validation error

Having received a data block, the sound level meter validates the data block (except where BCC = 00H). If the validation is incorrect, the sound level meter ignores the instruction.

### (3) Instruction error

The sound level meter probably does not recognise the instruction received, as the computer sent an unidentified instruction or there was an unexpected error during transmission. In case of an unexpected error, the sound level meter sends back the NAK block containing the error code 0001H.

### (4) Parameter error

The command block parameters can also contain errors: they may not be separated by a space, exceed the available range or include an incorrect quantity of arguments. In case of an unexpected error, the sound level meter sends back the NAK block containing the error code 0002H.

### (5) Unavailable under the current status

Incorrect operation under the current status is possible in the following cases:

1	A request for octave data return was received in the level meter mode or a request for level meter data return was received in the octave mode.
2	A calibration request was sent during measurement.
3	A request for a change of measurement or system parameters was sent during measurement.

In case of an unexpected error, the sound level meter sends back the NAK block containing the error code 0003H.

## 5.2.7 Flow control

The sound level meter is equipped with a 3-core interface with a 6-pin P/S2 port which does not include pins for data flow control by the hardware. The sound level meter does not support the programmed data flow control. The correct data sent and received can be ensured by operation in accordance with the requirements specified in [5.2.9 Nominal parameters](#).

## 5.2.8 Operation with several devices

Using the RS-232 interface, you can interconnect several sound level meters, thus creating a measurement network. You may change the settings of all the sound level

meters in an equivalent network using broadcast instructions, or access the data and parameters of each individual sound level meter using the regular commands.

Note that:

- (1) Sound level meters within the same network may never have the same IDs.
- (2) Using the broadcast instructions, you cannot send commands returning any data.

### 5.2.9 Nominal parameters

Name	Min.	Nominal value	Max.	Description
Sound level meter response time	—	—	2 s	When this value is exceeded, processing should be performed after exceeding the time.
Time interval for the instruction to send data to the sound level meter	—	100 ms	—	—
Sound level meter waiting time after receiving the <STX> command	—	unlimited	—	It means that the sound level meter always awaits the remaining data.
Time interval between each byte, in order for the sound level meter to receive the byte.	—	unlimited	—	It means that the computer sending speed may be very low.

### 5.3 Instructions

There are two types of instructions: setup instructions and query instructions.

**Setup instructions:** Define the measurement and system parameters of the sound level meter.

**Queries:** Ask about the parameters and data of the sound level meter.

There are three cases where the instructions are sent to the sound level meter: setup instructions (without response), setup instructions (with response), query instructions.

#### (1) Setup instructions (without response):

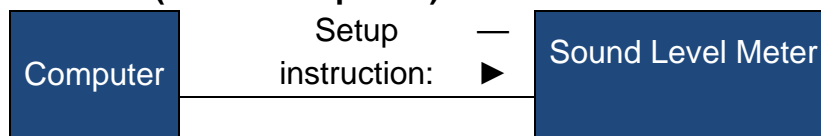

#### (2) Setup instructions (with response):

Acknowledge:

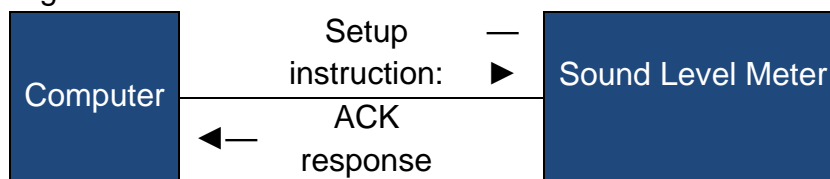

Negative acknowledge:



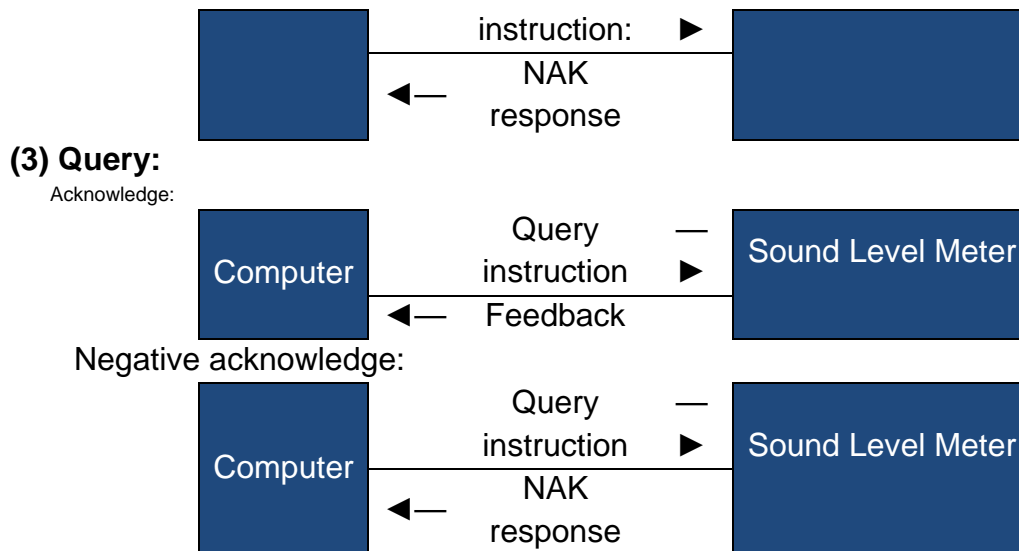

## 6. Operation guidelines

### 6.1 Operation

- Minimise the effect of vibration when using the sound level meter. Mechanical vibration may have an adverse impact on the indications at the lower measurement limit range, within the frequency range of the sound level meter (10 Hz to 20 kHz).
- Before the sound level meter is activated, it requires minimum 6 hours to adapt to the environmental conditions. After adapting and activating the sound level meter, the sound level measurement can be started immediately (no delay time is required).
- The measuring microphone is sensitive, handle it with care. Store the microphone in the supplied box to protect it against the environment.
- Follow the instructions and operation guidelines. Prevent fall, shocks and impact loads of the device. Operation exceeding the limits may cause damage.
- Prevent penetration of water or other liquids into the device, as it is not watertight.
- The use of high-quality alkaline batteries may extend the product service life and is beneficial to the device. Do not use old and new batteries at the same time. Take out the batteries if the device is not used. A battery which remains in the device for a long time may become unsealed and cause damage to the device.

### 6.2 Troubleshooting

Problem	Possible cause and solution
The device does not start.	<ul style="list-style-type: none"> <li>● Battery exhausted: change the battery.</li> <li>● Defect of the power unit: replace the power unit.</li> <li>● The ON/OFF key does not work: send the device to the manufacturer.</li> </ul>
Incorrect measurements.	Try to recalibrate the device.
No noticeable change of measurement data when the	<ul style="list-style-type: none"> <li>● Damaged microphone: send the microphone to the manufacturer.</li> </ul>

sound source was clearly changed.	<ul style="list-style-type: none"> <li>● Weak contact between the microphone and casing: send the casing to the manufacturer.</li> </ul>
A key does not work.	Damaged key: send the device to the manufacturer.
Slow response during operation.	Too many files in the microSD card: delete the damaged files.
Measurement data cannot be saved.	<ul style="list-style-type: none"> <li>● Check the logger settings.</li> <li>● Format the memory card with FAT32.</li> <li>● Replace the microSD card for a new memory card with a maximum capacity of 4 GB.</li> </ul>
The printer does not print the measurement data.	<ul style="list-style-type: none"> <li>● Check the printer settings.</li> <li>● Check if paper is properly placed in the printer.</li> </ul>

### 6.3 Calibration

The sound level meter is factory calibrated. Perform regular calibration to maintain the measuring accuracy. BSWA offers calibration services for acoustic products.

### 6.4 Firmware updating

The firmware of SW 1000/SW 2000 can be updated using the USB interface. The following equipment components must be available:

- the sound level meter SW 1000/SW 2000 must be deactivated (identifier HWID P0274 or higher),
- miniUSB cable (included in delivery),
- external power supply (included in delivery),
- updating firmware (to be downloaded from the BSWA website),
- USB driver (CP210x driver by Silicon Labs).

#### 6.4.1 Installation of USB driver

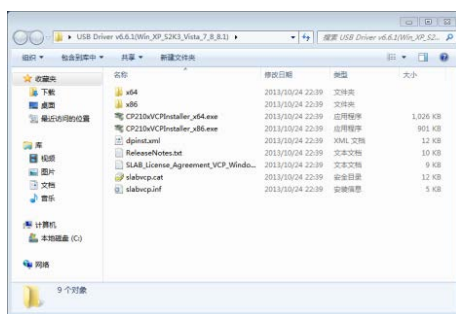

Unpack and install the driver according to the following procedure. Select the X86 version for a 32-bit operating system or the X64 version for a 64-bit operating system.

**☆ Hint:** Do not connect the sound level meter to the computer during installation.

Following the installation instructions, confirm the Licence Agreement and then click **Continue** until

the driver is installed.



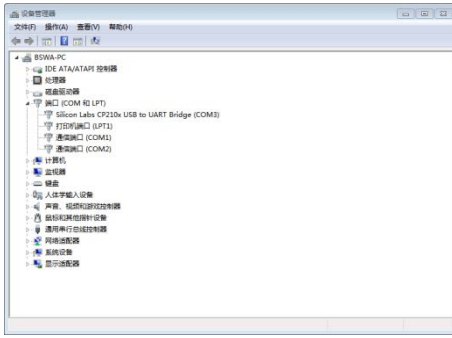

When the driver is installed, connect the sound level meter to the computer using the USB cable. The Device Manager will show a new device called **Silicon Labs CP210x USB to UART Bridge (COMx)**.

☆ **Hint:** When the sound level meter connects to the computer, power it up using an external power supply.

## 6.4.2 Firmware updating procedure



FlashTool Wizard used for firmware updating is very user-friendly. You just have to follow the procedure step by step.

Start FlashTool Wizard and choose the language.



**Step 1:** Prepare the firmware update list.

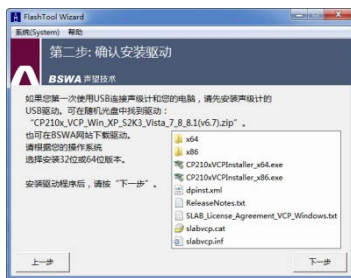

**Step 2:** Install the driver. Skip this step if the driver is already installed.



**Step 3:** Connect the sound level meter to the computer as per the user requirements. Note that the sound level meter requires an external power supply. If the driver works properly, it will automatically select the CP210x port. The standard **baud rate** is 115,200 bps, but it depends on the computer. A higher **baud rate** allows for a faster updating procedure.

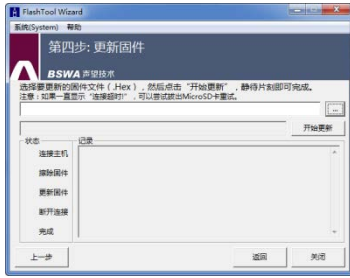

**Step 4:** Press the key located in the upper right corner to choose the firmware, and then press **Update** to start the program. The whole procedure takes 3 to 4 minutes.

☆ **Hint:** The device should be reset to the factory settings, and after updating the firmware perform at least one calibration, otherwise the sound level meter may work improperly. When the “Time Out!” message is shown

again, remove the microSD card and retry.

There are no limitations for updating or restoring an older firmware version, you can upgrade it to any version. However, we recommend that the previous firmware version is always stored. Do not hesitate to contact us by phone or e-mail to notify any problems or errors concerning the firmware.

☆ **Hint:** The firmware update option is only available in new sound level meters with HWID P0274 or higher. The models with the old identifier (HWID P0115) do not support the firmware update by the user. The list below presents the differences between the old and the new type;

- The **About** screen in model P0115 shows type 308/200, and in model P0274 — type 308S/200S.
- In model P0115, the RS-232 port is a 3-pin Lemo port, an in model P0274 — a 6-pin PS/2 port.
- In model P0115, the USB port does not work, in model P0274 it is available.
- Model P0115 provides two measuring ranges: “High” and “Low” (some products also support the automatic range), while model P0274 provides only one range.

## 6.5 Warranty

KERN offers warranty repairs in the warranty period. To remove any material, structural or production errors, components are replaced at KERN’s discretion.

Detailed information is provided in the Terms and Conditions of Warranty, contained in the commercial contract. The user may not open or repair the device. Any attempts to repair the product by unauthorised persons result in the loss of warranty.

## 6.6 Service Department telephone number

You can contact us in case of any problems.

Service Department telephone number	
Sales Department telephone number	

## Appendix 1

### Glossary

- **Frequency weighting<sup>1</sup>:** Difference in the frequency function between the signal level, weighted according to the frequency response and shown on the display, and the corresponding level of a fixed sinusoidal input signal. The level difference is specified in decibels (dB). The frequency weighting usually determines the A, B, C and D weightings, which allow for a simulation of human hearing frequency re-

sponse. The A and C weightings are used more often and defined in IEC and GB/T standards. The B weighting is only defined in ANSI standard. The D weighting refers to an international standard that is already invalidated. The D weighting is only available in some old devices. No frequency response (the so-called flat response) is always defined as Z response, flat response or linear response.

- **Time constant<sup>1</sup>**: Exponential time function for a certain time constant, which corrects the square of sound level value. The acoustic pressure correction is higher if it better corresponds to the current time, and vice versa. The most popular time constants are “Fast” and “Slow”. Do not use the “Pulse” option, it is only available for historical purposes.
- **SPL**: Sound pressure level (SPL), calculated by the sound level meter, is the maximum level of sound weighted according to the time constant, measured in one second.
- **LEQ<sup>1</sup>**: Average sound level value or an equivalent constant level of sound during measurement. The value equal to 10 common logarithms from the ratio of the square of average sound pressure signal time, weighted according to the frequency response at a specific time interval, to the square of LEQ reference value, constitutes the current value of integrating the sound level during the given period of measurement. The longer the integration time, the slower the LEQ change. The LEQ parameter is often used for comprehensive assessment of noise load.
- **Peak<sup>1</sup>**: Peak value of sound level. The value equal to 10 common logarithms from the ratio of the square of maximum sound pressure level, weighted according to the frequency response, to the square of reference value. Generally, this value is used to assess very short sound pulses.
- **E<sup>1</sup>**: Noise load (sound exposure level). The integral of the time of sound pressure level signal square, weighted according to the frequency response, at a defined time interval or an event with a defined duration of measurement. This value is always used to assess the impact of noise on people.
- **SEL<sup>1</sup>**: Noise load (sound exposure level). The value of 10 common logarithms from the ratio of noise load to reference value. It is sometimes called “single event level”.
- **LN**: Statistical result of analysis (statistical level). The noise level exceeded in N% of measurement period.
- **Max<sup>1</sup>**: Maximum time of weighted sound level at a given measurement period.
- **Min**: Minimum time of weighted sound level at a given measurement period.
- **SD**: Standard deviation of sound level, weighted according to the time constant, at a given measurement period. The SD parameter is used to define the degree of changes in sound level broadcasting.

Hint 1: Further details are provided in the definitions contained in IEC 61672.1:2013.

## Appendix 2

### Weightings for the sound level meter and sound broadcasting around the microphone at typical building reflections

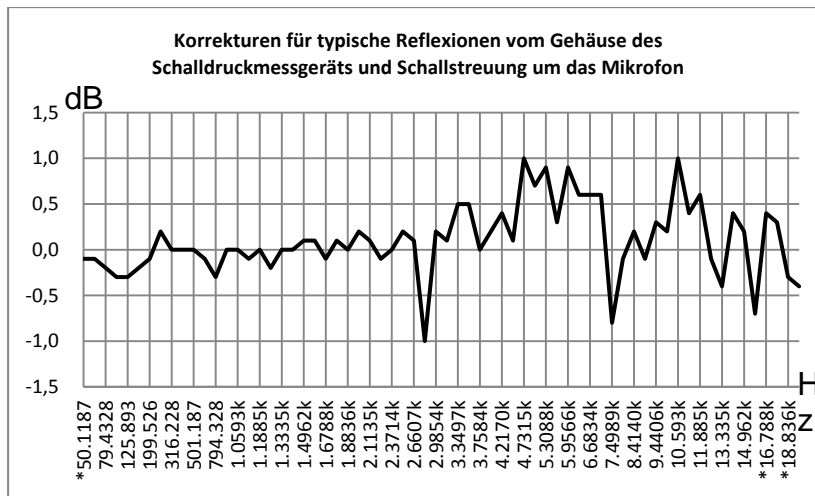

Fre- quency [Hz]	Valu e [dB]	Fre- quency [Hz]	Valu e [dB]	Fre- quency [Hz]	Valu e [dB]	Fre- quency [Hz]	Valu e [dB]	Fre- quency [Hz]	Valu e [dB]	Fre- quency [Hz]	Valu e [dB]
*50.119	-0.1	630.96	-0.1	1678.8	-0.1	3162.3	0.1	5956.6	0.9	11,220	0.4
63.096	-0.1	794.33	-0.3	1778.3	0.1	3349.7	0.5	6200.6	0.6	11,885	0.6
79.433	-0.2	1000.0	0.0	1883.6	0.0	3548.1	0.5	6683.4	0.6	12,589	-0.1
100.00	-0.3	1059.3	0.0	1995.3	0.2	3758.4	0.0	7079.5	0.6	13,335	-0.4
125.89	-0.3	1122.0	-0.1	2113.5	0.1	3981.1	0.2	7498.9	-0.8	14,125	0.4
158.49	-0.2	1188.5	0.0	2238.7	-0.1	4217.0	0.4	7943.3	-0.1	14,962	0.2
199.53	-0.1	1258.9	-0.2	2371.4	0.0	4466.8	0.1	8414.0	0.2	15,849	-0.7
251.19	0.2	1333.5	0.0	2511.9	0.2	4731.5	1.0	8912.5	-0.1	*16,788	0.4
316.23	0.0	1412.5	0.0	2660.7	0.1	5011.9	0.7	9440.6	0.3	*17,783	0.3
398.11	0.0	1496.2	0.1	2818.4	-1.0	5308.8	0.9	10,000	0.2	*18,836	-0.3
501.19	0.0	1584.9	0.1	2985.4	0.2	5623.4	0.3	10,593	1.0	*19,953	-0.4

Extended uncertainties:  $U = 0.17$  ( $k = 2$ ) for frequencies  $\leq 4$  kHz,  $U = 0.29$  ( $k = 2$ ) for frequencies  $> 4$  kHz

Hint: The frequency marked with \* is not recommended in the standard, the exact frequency is specified in IEC 61672-1.



## Appendix 3

### Weightings related to the use of a wind shield outdoors

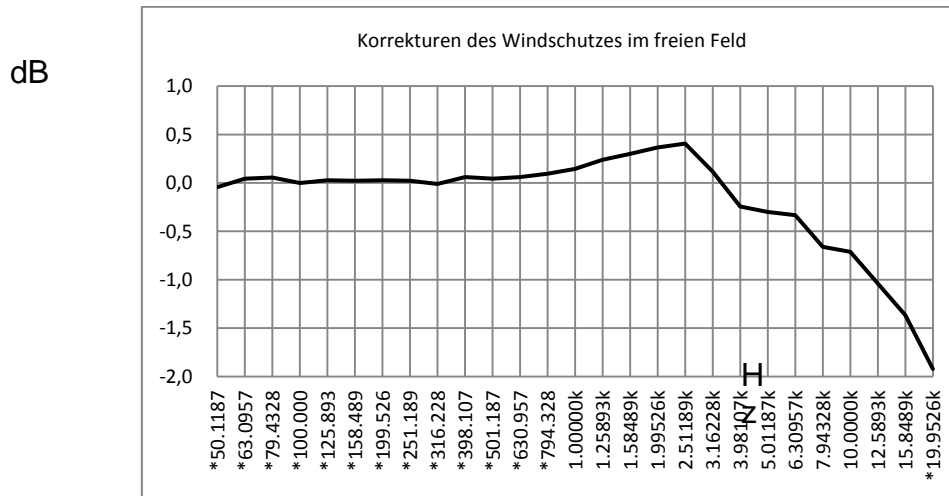

Frequency [Hz]	Value [dB]	Frequency [Hz]	Value [dB]	Frequency [Hz]	Value [dB]
*50.119	-0.04	*398.11	0.06	3162.3	0.12
*63.096	0.04	*501.19	0.04	3981.1	-0.24
*79.433	0.06	*630.96	0.06	5011.9	-0.30
*100.00	0.00	*794.33	0.09	6200.6	-0.33
*125.89	0.03	1000.0	0.14	7943.3	-0.66
*158.49	0.02	1258.9	0.24	10,000	-0.71
*199.53	0.03	1584.9	0.30	12,589	-1.04
*251.19	0.02	1995.3	0.37	15,849	-1.37
*316.23	-0.01	2511.9	0.41	*19,953	-1.92

Extended uncertainties:  $U = 0.15$  ( $k = 2$ ) for frequencies  $\leq 4$  kHz,  $U = 0.21$  ( $k = 2$ ) for frequencies  $> 4$  kHz.

Hint: The frequency marked with \* is not recommended in the standard, the exact frequency is specified in IEC 61672-1.

## Appendix 4

### Electret microphone weightings

The weightings given below were measured with an electret microphone and power supply.

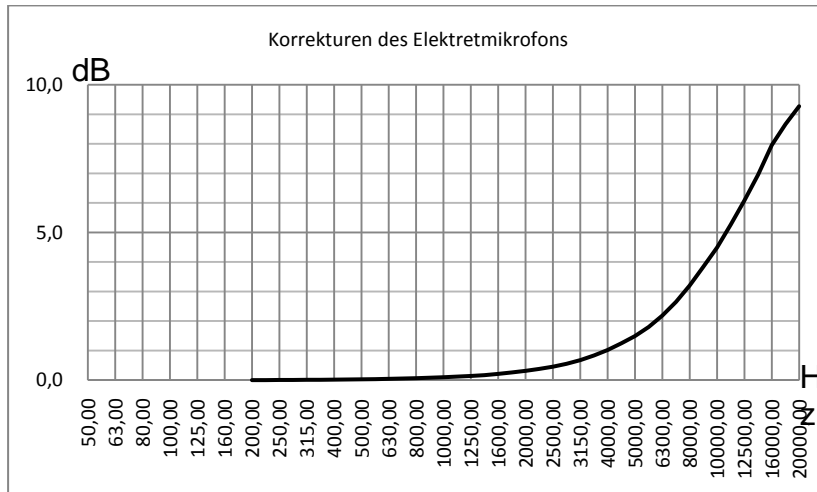

Frequency [Hz]	Value [dB]	Frequency [Hz]	Value [dB]	Frequency [Hz]	Value [dB]	Frequency [Hz]	Value [dB]
200	0.000	630	0.043	2000	0.312	6300	2.184
224	0.002	710	0.053	2240	0.378	7100	2.651
250	0.004	800	0.065	2500	0.456	8000	3.204
280	0.006	900	0.080	2800	0.554	9000	3.840
315	0.009	1000	0.096	3150	0.678	10,000	4.488
355	0.013	1120	0.116	3550	0.832	11,200	5.264
400	0.017	1250	0.140	4000	1.020	12,500	6.081
450	0.022	1400	0.170	4500	1.245	14,000	6.960
500	0.027	1600	0.213	5000	1.488	16,000	7.956
560	0.034	1800	0.260	5600	1.798	18,000	8.664
						20,000	9.272

Extended uncertainties:  $U = 0.19$  ( $k = 2$ ) for frequencies  $\leq 4$  kHz,  $U = 0.34$  ( $k = 2$ ) for frequencies of 4 kHz to 10 kHz,  $U = 0.39$  ( $k = 2$ ) for frequencies  $\geq 10$  kHz.

## Appendix 5

### Typical frequency response and corresponding upper limits

Prior to shipment, each microphone is carefully checked at the factory. The calibration diagram contained in the box presents the actual frequency response of the electret microphone and the frequency response measured outdoors.

Typical frequency response with frequency weighting for the sound level meter is presented in the figure below. The typical frequency response and microphone frequency response measured outdoors can be regarded as the total response of the sound level meter to be used outdoors. The Calibration Certificate also contains the test results of frequency response with A, C and Z weightings.

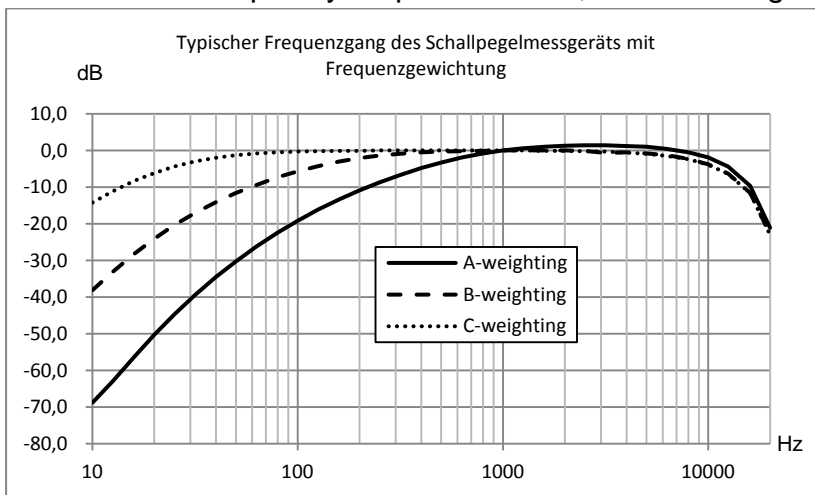

The table below presents the impact of the upper limit of measuring range with A, B and C weightings and the typical frequency response shown in the figure:

Frequency [Hz]	31.5	63	125	250	500	1 k	2 k	4 k	8 k	16 k*
A-weighting [dB]	-39.5	-26.2	-16.2	-8.7	-3.3	0.0	+1.3	+1.2	-0.5	-9.7
B-weighting [dB]	-17.1	-9.4	-4.3	-1.4	-0.3	0.0	0.0	-0.5	-2.3	-11.6
C-weighting [dB]	-3.0	-0.8	-0.2	0.0	0.0	0.0	-0.1	-0.6	-2.4	-11.7

Hint\*: Available only in SW 1000.

## Appendix 6

### Technical data of 1/1-octave filter

The 1/1-octave filter was developed based on the Butterworth filter, grade 10. The technical data for each filter are presented in the following figure.

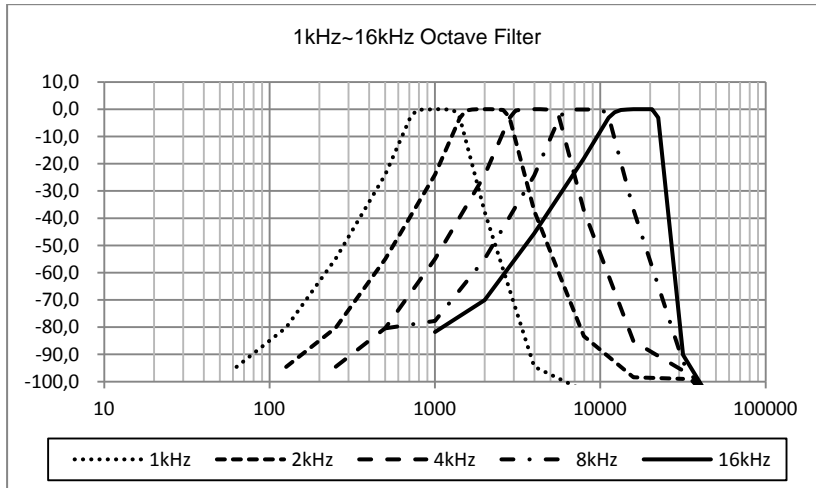
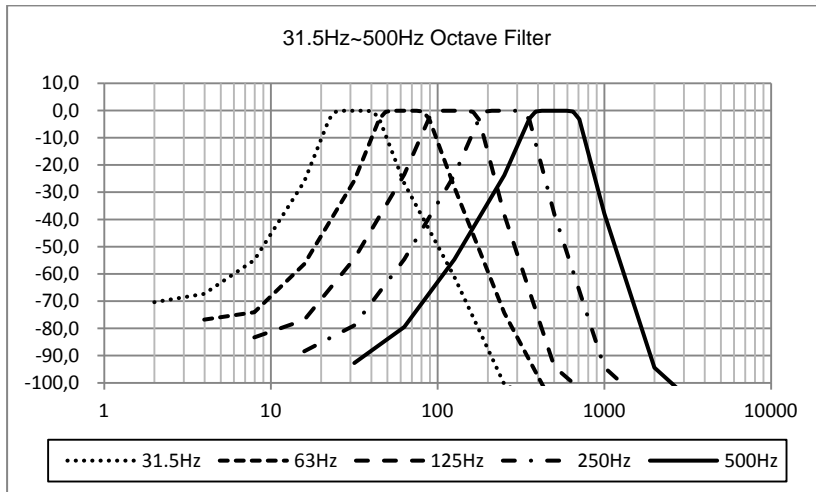

Annotation:

To have a look at the CE Declaration of Conformity, please click onto the following link: <https://www.kern-sohn.com/shop/de/DOWNLOADS/>